

**PHILIPPINE
PORTS
AUTHORITY**



**Repair of Damaged R.C. Pier, Concrete Pavement
Approach, Slope Protection, Back-up Area and
Removal of Sunken Derelicts/Logs, Port of Rizal,
Brgy. Puntabaja, Rizal, Palawan
(NRP-PLW-02-2021)**

BID DOCUMENTS
September 2021

TABLE OF CONTENTS

Glossary of Terms, Abbreviations, and Acronyms	3
Section I. Invitation to Bid	8
Section II. Instructions to Bidders	9
1. Scope of Bid	
2. Funding Information	
3. Bidding Requirements	
4. Corrupt, Fraudulent, Collusive, Coercive, and Obstructive Practices	
5. Eligible Bidders	
6. Origin of Associated Goods	
7. Subcontracts	
8. Pre-Bid Conference	
9. Clarification and Amendment of Bidding Documents	
10. Documents Comprising the Bid: Eligibility and Technical Components	
11. Documents Comprising the Bid: Financial Component	
12. Alternative Bids	
13. Bid Prices	
14. Bid and Payment Currencies	
15. Bid Security	
16. Sealing and Marking of Bids	
17. Deadline for Submission of Bids	
18. Opening and Preliminary Examination of Bids	
19. Detailed Evaluation and Comparison of Bids	
20. Post Qualification	
21. Signing of the Contract	
Section III. Bid Data Sheet	16
Section IV. General Conditions of Contract	18
1. Scope of Contract	
2. Sectional Completion of Works	
3. Possession of Site	
4. The Contractor's Obligations	
5. Performance Security	
6. Site Investigation Reports	
7. Warranty	
8. Liability of the Contractor	
9. Termination for Other Causes	
10. Dayworks	
11. Program of Work	
12. Instructions, Inspections and Audits	
13. Advance Payment	
14. Progress Payments	
15. Operating and Maintenance Manuals	
Section V. Special Conditions of Contract	22
Section VI. Specifications	24
Section VII. Drawings	57
Section VIII. Bill of Quantities	68
Section IX. Checklist of Technical and Financial Documents	68
Section X. Bidding Forms	69



**GLOSSARY OF
TERMS,
ABBREVIATIONS, AND
ACRONYMS**

Glossary of Terms, Abbreviations, and Acronyms

ABC – Approved Budget for the Contract.

ARCC – Allowable Range of Contract Cost.

BAC – Bids and Awards Committee.

Bid – A signed offer or proposal to undertake a contract submitted by a bidder in response to and in consonance with the requirements of the bidding documents. Also referred to as *Proposal and Tender*. (2016 revised IRR, Section 5[c])

Bidder – Refers to a contractor, manufacturer, supplier, distributor and/or consultant who submits a bid in response to the requirements of the Bidding Documents. (2016 revised IRR, Section 5[d])

Bidding Documents – The documents issued by the Procuring Entity as the bases for bids, furnishing all information necessary for a prospective bidder to prepare a bid for the Goods, Infrastructure Projects, and/or Consulting Services required by the Procuring Entity. (2016 revised IRR, Section 5[e])

BIR – Bureau of Internal Revenue.

BSP – Bangko Sentral ng Pilipinas.

CDA – Cooperative Development Authority.

Consulting Services – Refer to services for Infrastructure Projects and other types of projects or activities of the GOP requiring adequate external technical and professional expertise that are beyond the capability and/or capacity of the GOP to undertake such as, but not limited to: (i) advisory and review services; (ii) pre-investment or feasibility studies; (iii) design; (iv) construction supervision; (v) management and related services; and (vi) other technical services or special studies. (2016 revised IRR, Section 5[f])

Contract – Refers to the agreement entered into between the Procuring Entity and the Supplier or Manufacturer or Distributor or Service Provider for procurement of Goods and Services; Contractor for Procurement of Infrastructure Projects; or Consultant or Consulting Firm for Procurement of Consulting Services; as the case may be, as recorded in the Contract Form signed by the parties, including all attachments and appendices thereto and all documents incorporated by reference therein.

Contractor – is a natural or juridical entity whose proposal was accepted by the Procuring Entity and to whom the Contract to execute the Work was awarded. Contractor as used in these Bidding Documents may likewise refer to a supplier, distributor, manufacturer, or consultant.

CPI – Consumer Price Index.

DOLE – Department of Labor and Employment.

DTI – Department of Trade and Industry.

Foreign-funded Procurement or Foreign-Assisted Project – Refers to procurement whose funding source is from a foreign government, foreign or international financing institution as specified in the Treaty or International or Executive Agreement. (2016 revised IRR, Section 5[b]).

GFI – Government Financial Institution.

GOCC – Government-owned and/or –controlled corporation.

Goods – Refer to all items, supplies, materials and general support services, except Consulting Services and Infrastructure Projects, which may be needed in the transaction of public businesses or in the pursuit of any government undertaking, project or activity, whether in the nature of equipment, furniture, stationery, materials for construction, or personal property of any kind, including non-personal or contractual services such as the repair and maintenance of equipment and furniture, as well as trucking, hauling, janitorial, security, and related or analogous services, as well as procurement of materials and supplies provided by the Procuring Entity for such services. The term "related" or "analogous services" shall include, but is not limited to, lease or purchase of office space, media advertisements, health maintenance services, and other services essential to the operation of the Procuring Entity. (2016 revised IRR, Section 5[r])

GOP – Government of the Philippines.

Infrastructure Projects – Include the construction, improvement, rehabilitation, demolition, repair, restoration or maintenance of roads and bridges, railways, airports, seaports, communication facilities, civil works components of information technology projects, irrigation, flood control and drainage, water supply, sanitation, sewerage and solid waste management systems, shore protection, energy/power and electrification facilities, national buildings, school buildings, hospital buildings, and other related construction projects of the government. Also referred to as *civil works or works*. (2016 revised IRR, Section 5[u])

LGUs – Local Government Units.

NFCC – Net Financial Contracting Capacity.

NGA – National Government Agency.

PCAB – Philippine Contractors Accreditation Board.

PhilGEPS – Philippine Government Electronic Procurement System.

Procurement Project – refers to a specific or identified procurement covering goods, infrastructure project or consulting services. A Procurement Project shall be described, detailed, and scheduled in the Project Procurement Management Plan prepared by the agency which shall be consolidated in the procuring entity's Annual Procurement Plan. (GPPB Circular No. 06-2019 dated 17 July 2019)

PSA – Philippine Statistics Authority.

SEC – Securities and Exchange Commission.

SLCC – Single Largest Completed Contract.

UN – United Nations.

Section I.
Invitation to Bid



**Invitation to Bid
for the**

Repair of Damaged R.C. Pier, Concrete Pavement Approach, Slope Protection, Back-up Area and Removal of Sunken Derelicts/Logs, Port of Rizal, Brgy. Puntabaja, Rizal, Palawan

1. The **Philippine Ports Authority PMO Palawan**, through the **Corporate Budget of the Authority for CY 2021** intends to apply the sum of **Php 15,290,175.82** being the **Approved Budget for the Contract (ABC)** to payments under the contract for **Repair of Damaged R.C. Pier, Concrete Pavement Approach, Slope Protection, Back-up Area and Removal of Sunken Derelicts/Logs, Port of Rizal, Brgy. Puntabaja, Rizal, Palawan**. Bids received in excess of the **ABC** shall be automatically rejected at bid opening.
2. The **Philippine Ports Authority PMO Palawan** now invites bids for the above **Procurement Project**. Completion of the Works is required **Two Hundred Forty (240) Calendar Days** from the receipt by the successful Bidder of the Notice to Proceed. Bidders should have completed a contract similar to the Project. The description of an eligible bidder is contained in the Bidding Documents, particularly, in Section II (Instructions to Bidders).
3. Bidding will be conducted through open competitive bidding procedures using non-discretionary "pass/fail" criterion as specified in the 2016 revised Implementing Rules and Regulations (IRR) of Republic Act (RA) No. 9184.
4. Interested bidders may obtain further information from **Philippine Ports Authority PMO Palawan Bids and Awards Committee** and inspect the Bidding Documents at the address given below from **8:00 A.M. to 5:00 P.M., Monday to Friday**.
5. A complete set of Bidding Documents may be acquired by interested bidders on **September 1, 2021 to September 20, 2021** from given address and website/s below and upon payment of the applicable fee for the Bidding Documents, pursuant to the latest Guidelines issued by the GPPB, in the amount of **Twenty Five Thousand Pesos (Php 25,000.00)**. The Procuring Entity shall allow the bidder to present its proof of payment for the fees *in person*.
6. The **Philippine Ports Authority PMO Palawan Bids and Awards Committee** will hold a Pre-Bid Conference on **September 8, 2021, 2:30 P.M.** at Conference Room, 2nd Floor, PPA Administrative Building, Port Area, Puerto Princesa City and/or through videoconferencing/webcasting *via Zoom*, which shall be open to prospective bidders.
7. Bids must be duly received by the BAC Secretariat through manual submission at the office address as indicated below on or before **9:00 A.M. of September 20, 2021**. Late bids shall not be accepted.
8. All bids must be accompanied by a bid security in any of the acceptable forms and in the amount stated in ITB Clause 15.

9. Bid opening shall be on **September 20, 2021, 10:00 A.M.** at Conference Room, 2nd Floor, PPA PMO–Palawan Administrative Building, Port Area, Puerto Princesa City. Bids will be opened in the presence of the bidders' representatives who choose to attend the activity.

10. The **Philippine Ports Authority** reserves the right to reject any and all bids, declare a failure of bidding, or not award the contract at any time prior to contract award in accordance with Sections 35.6 and 41 of the 2016 revised Implementing Rules and Regulations (IRR) of RA No. 9184, without thereby incurring any liability to the affected bidder or bidders.

- **Required PCAB Registration (Minimum): SMALL B - Harbor & Offshore Engineering**

11. For further information, please refer to:

MARIZA O. NALLANA
Head Secretariat
PMO Palawan BAC
Port Area, Puerto Princesa City,
Telephone No.: (048) 433-0356 or (048) 716-6864
Email Address: pmopalawanbac@gmail.com

12. You may visit the following websites:

PPA website: www.ppa.com.ph
PhilGEPS website: www.philgeps.gov.ph

September 1, 2021

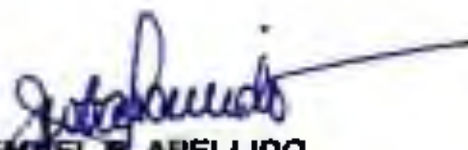
JEMBEL B. APELLIDO
Chairperson
PPA PMO-Palawan
Bids and Awards Committee
For Goods, Infrastructure & Consultancy
Projects



Section II.
Instructions to Bidders

1. Scope of Bid

The Procuring Entity, **Philippine Ports Authority PMO Palawan** invites Bids for the **Repair of Damaged R.C. Pier, Concrete Pavement Approach, Slope Protection, Back-up Area and Removal of Sunken Derelicts/Logs, Port of Rizal, Brgy. Puntabaja, Rizal, Palawan, with Project Identification Number NRP-PLW-02-2021.**

The **Repair of Damaged R.C. Pier, Concrete Pavement Approach, Slope Protection, Back-up Area and Removal of Sunken Derelicts/Logs, Port of Rizal, Brgy. Puntabaja, Rizal, Palawan** (referred to herein as "Project") is for the construction of Works, as described in Section VI (Specifications).

2. Funding Information

2.1 The **Philippine Ports Authority** through the source of funding as indicated below for **CY 2021** in the amount of **Php 15,290,175.82**.

2.2 The source of funding is:

a. Corporate Operating Budget.

3. Bidding Requirements

The Bidding for the Project shall be governed by all the provisions of RA No. 9184 and its 2016 revised IRR, including its Generic Procurement Manual and associated policies, rules and regulations as the primary source thereof, while the herein clauses shall serve as the secondary source thereof.

Any amendments made to the IRR and other GPPB issuances shall be applicable only to the ongoing posting, advertisement, or invitation to bid by the BAC through the issuance of a supplemental or bid bulletin.

The Bidder, by the act of submitting its Bid, shall be deemed to have inspected the site, determined the general characteristics of the contracted Works and the conditions for this Project, such as the location and the nature of the work; (b) climatic conditions; (c) transportation facilities; (c) nature and condition of the terrain, geological conditions at the site communication facilities, requirements, location and availability of construction aggregates and other materials, labor, water, electric power and access roads; and (d) other factors that may affect the cost, duration and execution or implementation of the contract, project, or work and examine all instructions, forms, terms, and project requirements in the Bidding Documents.

4. Corrupt, Fraudulent, Collusive, Coercive, and Obstructive Practices

The Procuring Entity, as well as the Bidders and Contractors, shall observe the highest standard of ethics during the procurement and execution of the contract. They or through an agent shall not engage in corrupt, fraudulent, collusive, coercive, and obstructive practices defined under Annex "I" of the 2016 revised IRR of RA No. 9184 or other integrity violations in competing for the Project.

5. Eligible Bidders

5.1 Only Bids of Bidders found to be legally, technically, and financially capable will be evaluated.

5.2 The Bidder must have an experience of having completed a Single Largest Completed Contract (SLCC) that is similar to this Project, equivalent to at least fifty percent (50%) of the ABC adjusted, if necessary, by the Bidder to current

A contract is considered to be "similar" to the contract to be bid if it has the major categories of work stated in the **BDS**.

5.3 For Foreign-funded Procurement, the Procuring Entity and the foreign government/foreign or international financing institution may agree on another track record requirement, as specified in the Bidding Document prepared for this purpose.

5.4. The Bidders shall comply with the eligibility criteria under Section

5.5. 23.4.2 of the 2016 IRR of RA No. 9184.

6. Origin of Associated Goods

There is no restriction on the origin of Goods other than those prohibited by a decision of the UN Security Council taken under Chapter VII of the Charter of the UN.

7. Subcontracts

7.1. The Bidder may subcontract portions of the Project to the extent allowed by the Procuring Entity as stated herein, but in no case more than fifty percent (50%) of the Project.

The Procuring Entity has prescribed that:

a. Subcontracting is not allowed.

7.2 Subcontracting of any portion of the Project does not relieve the Contractor of any liability or obligation under the Contract. The Supplier will be responsible for the acts, defaults, and negligence of any subcontractor, its agents, servants, or workmen as fully as if these were the Contractor's own acts, defaults, or negligence, or those of its agents, servants, or workmen.

8. Pre-Bid Conference

The Procuring Entity will hold a pre-bid conference for this Project on the specified date and time and either at its physical address **Philippine Ports Authority PMO Palawan, Port Area, Puerto Princesa City, Palawan** and/or through videoconferencing/webcasting) as indicated in paragraph 6 of the **IB**.

9. Clarification and Amendment of Bidding Documents

Prospective bidders may request for clarification on and/or interpretation of any part of the Bidding Documents. Such requests must be in writing and received by the Procuring Entity, either at its given address or through electronic mail indicated in the **IB**, at least ten (10) calendar days before the deadline set for the submission and receipt of Bids

10. Documents Comprising the Bid: Eligibility and Technical Components

10.1. The first envelope shall contain the eligibility and technical documents of the Bid as specified in **Section IX. Checklist of Technical and Financial Documents**.

10.2. If the eligibility requirements or statements, the bids, and all other documents for submission to the BAC are in foreign language other than English, it must be accompanied by a translation in English, which shall be authenticated by the appropriate Philippine foreign service establishment, post, or the equivalent office having jurisdiction over the foreign bidder's affairs in the Philippines. For Contracting Parties to the Apostille Convention, only the translated documents shall be authenticated through an apostille pursuant to GPPB Resolution No. 13-2019 dated 23 May 2019. The English translation shall govern, for purposes of interpretation of the bid.

- 10.3. A valid PCAB License is required, and in case of joint ventures, a valid special PCAB License, and registration for the type and cost of the contract for this Project. Any additional type of Contractor license or permit shall be indicated in the **BDS**.
- 10.4. A List of Contractor's key personnel (e.g., Project Manager, Project Engineers, Materials Engineers, and Foremen) assigned to the contract to be bid, with their complete qualification and experience data shall be provided. These key personnel must meet the required minimum years of experience set in the **BDS**.
- 10.5. A List of Contractor's major equipment units, which are owned, leased, and/or under purchase agreements, supported by proof of ownership, certification of availability of equipment from the equipment lessor/vendor for the duration of the project, as the case may be, must meet the minimum requirements for the contract set in the **BDS**.

11. Documents Comprising the Bid: Financial Component

- 11.1. The second bid envelope shall contain the financial documents for the Bid as specified in **Section IX. Checklist of Technical and Financial Documents**.
- 11.2. Any bid exceeding the ABC indicated in paragraph 1 of the **IB** shall not be accepted.
- 11.3. For Foreign-funded procurement, a ceiling may be applied to bid prices provided the conditions are met under Section 31.2 of the 2016 revised IRR of RA No. 9184.

12. Alternative Bids

Bidders shall submit offers that comply with the requirements of the Bidding Documents, including the basic technical design as indicated in the drawings and specifications. Unless there is a value engineering clause in the **BDS**, alternative Bids shall not be accepted.

13. Bid Prices

All bid prices for the given scope of work in the Project as awarded shall be considered as fixed prices, and therefore not subject to price escalation during contract implementation, except under extraordinary circumstances as determined by the NEDA and approved by the GPPB pursuant to the revised Guidelines for Contract Price Escalation guidelines.

14. Bid and Payment Currencies

14.1. Bid prices may be quoted in the local currency or tradeable currency accepted by the BSP at the discretion of the Bidder. However, for purposes of bid evaluation, Bids denominated in foreign currencies shall be converted to Philippine currency based on the exchange rate as published in the BSP reference rate bulletin on the day of the bid opening.

14.2. *Payment of the contract price shall be made in:*

- a. Philippine Pesos.

15. Bid Security

15.1. The Bidder shall submit a Bid Securing Declaration or any form of Bid Security in the amount indicated in the **BDS**, which shall be not less than the percentage of the ABC in accordance with the schedule in the **BDS**.

- 15.2. The Bid and bid security shall be valid until **One Hundred Twenty (120) days from the date set for Bid Opening**. Any bid not accompanied by an acceptable bid security shall be rejected by the Procuring Entity as non-responsive.

16. Sealing and Marking of Bids

Each Bidder shall submit one copy of the first and second components of its Bid.

The Procuring Entity may request additional hard copies and/or electronic copies of the Bid. However, failure of the Bidders to comply with the said request shall not be a ground for disqualification.

If the Procuring Entity allows the submission of bids through online submission to the given website or any other electronic means, the Bidder shall submit an electronic copy of its Bid, which must be digitally signed. An electronic copy that cannot be opened or is corrupted shall be considered non-responsive and, thus, automatically disqualified.

17. Deadline for Submission of Bids

The Bidders shall submit on the specified date and time and either at its physical address or through online submission as indicated in paragraph 7 of the IB.

18. Opening and Preliminary Examination of Bids

- 18.1. The BAC shall open the Bids in public at the time, on the date, and at the place specified in paragraph 9 of the IB. The Bidders' representatives who are present shall sign a register evidencing their attendance. In case videoconferencing, webcasting or other similar technologies will be used, attendance of participants shall likewise be recorded by the BAC Secretariat.

In case the Bids cannot be opened as scheduled due to justifiable reasons, the rescheduling requirements under Section 29 of the 2016 revised IRR of RA No. 9184 shall prevail.

- 18.2. The preliminary examination of Bids shall be governed by Section 30 of the 2016 revised IRR of RA No. 9184.

19. Detailed Evaluation and Comparison of Bids

- 19.1. The Procuring Entity's BAC shall immediately conduct a detailed evaluation of all Bids rated "passed" using non-discretionary pass/fail criteria. The BAC shall consider the conditions in the evaluation of Bids under Section 32.2 of 2016 revised IRR of RA No. 9184.

- 19.2. If the Project allows partial bids, all Bids and combinations of Bids as indicated in the BDS shall be received by the same deadline and opened and evaluated simultaneously so as to determine the Bid or combination of Bids offering the lowest calculated cost to the Procuring Entity. Bid Security as required by ITB Clause 16 shall be submitted for each contract (lot) separately.

- 19.3. In all cases, the NFCC computation pursuant to Section 23.4.2.6 of the 2016 revised IRR of RA No. 9184 must be sufficient for the total of the ABCs for all the lots participated in by the prospective Bidder.

20. Post Qualification

Within a non-extendible period of five (5) calendar days from receipt by the Bidder of the notice from the BAC that it submitted the Lowest Calculated Bid, the Bidder shall submit its latest income and business tax returns filed and paid through the BIR Electronic Filing and Payment System (eFPS), and other appropriate licenses and permits required by law and stated in the BDS.

21. Signing of the Contract

The documents required in Section 37.2 of the 2016 revised IRR of RA No. 9184 shall form part of the Contract. Additional Contract documents are indicated in the **BDS**.



Section III.
Bid Data Sheet

Bid Data Sheet

ITB Clause																																																																																	
5.2	<p>For this purpose, contracts similar to the Project refer to contracts which have the same major categories of work, which shall be:</p> <table border="1" style="width: 100%; border-collapse: collapse;"> <thead> <tr> <th style="text-align: left;">Major Categories of Work</th> <th style="text-align: left;">Unit of Measure</th> <th style="text-align: right;">Required Quantity (50% of BOQ)</th> </tr> </thead> <tbody> <tr> <td>1. Demolition Works</td> <td>Cu.m.</td> <td style="text-align: right;">62.00</td> </tr> <tr> <td>2. Rockworks</td> <td>Cu m</td> <td style="text-align: right;">152.00</td> </tr> <tr> <td>3. Supply, Spread & Compact Aggregate Base Course</td> <td>Cum</td> <td style="text-align: right;">19.00</td> </tr> <tr> <td>4. Reinforcing Steel Bars</td> <td>Kgs</td> <td style="text-align: right;">14,176.00</td> </tr> <tr> <td>5. Concrete Works</td> <td>Cu m.</td> <td style="text-align: right;">192.00</td> </tr> <tr> <td>6. Supply & Install RCF</td> <td>unit</td> <td style="text-align: right;">3.00</td> </tr> <tr> <td>7. Supply & Install Mooring</td> <td>unit</td> <td style="text-align: right;">1.00</td> </tr> </tbody> </table>	Major Categories of Work	Unit of Measure	Required Quantity (50% of BOQ)	1. Demolition Works	Cu.m.	62.00	2. Rockworks	Cu m	152.00	3. Supply, Spread & Compact Aggregate Base Course	Cum	19.00	4. Reinforcing Steel Bars	Kgs	14,176.00	5. Concrete Works	Cu m.	192.00	6. Supply & Install RCF	unit	3.00	7. Supply & Install Mooring	unit	1.00																																																								
Major Categories of Work	Unit of Measure	Required Quantity (50% of BOQ)																																																																															
1. Demolition Works	Cu.m.	62.00																																																																															
2. Rockworks	Cu m	152.00																																																																															
3. Supply, Spread & Compact Aggregate Base Course	Cum	19.00																																																																															
4. Reinforcing Steel Bars	Kgs	14,176.00																																																																															
5. Concrete Works	Cu m.	192.00																																																																															
6. Supply & Install RCF	unit	3.00																																																																															
7. Supply & Install Mooring	unit	1.00																																																																															
7.1	Subcontracting is not allowed																																																																																
10.3	For Joint Venture : Special PCAB License																																																																																
10.4	<p>The key personnel must meet the required minimum years of experience set below:</p> <table border="1" style="width: 100%; border-collapse: collapse;"> <thead> <tr> <th style="text-align: left;">Key Personnel</th> <th style="text-align: left;">General Experience</th> <th style="text-align: left;">Relevant Experience</th> </tr> </thead> <tbody> <tr> <td>1) Project Manager</td> <td>Infrastructure/Civil Works</td> <td>Building Construction</td> </tr> <tr> <td>2) Project Engineer</td> <td>Infrastructure/Civil Works</td> <td>Building Construction</td> </tr> <tr> <td>3) Materials Engineer</td> <td>Infrastructure/Civil Works</td> <td>Building Construction</td> </tr> <tr> <td>4) Safety and Health Officer</td> <td>Infrastructure/Civil Works</td> <td>Building Construction</td> </tr> <tr> <td>5) Foreman</td> <td>Infrastructure/Civil Works</td> <td>Building Construction</td> </tr> </tbody> </table> <p>NOTE: Required Personnel minimum years of experiences: at least two (2) years of experience</p>	Key Personnel	General Experience	Relevant Experience	1) Project Manager	Infrastructure/Civil Works	Building Construction	2) Project Engineer	Infrastructure/Civil Works	Building Construction	3) Materials Engineer	Infrastructure/Civil Works	Building Construction	4) Safety and Health Officer	Infrastructure/Civil Works	Building Construction	5) Foreman	Infrastructure/Civil Works	Building Construction																																																														
Key Personnel	General Experience	Relevant Experience																																																																															
1) Project Manager	Infrastructure/Civil Works	Building Construction																																																																															
2) Project Engineer	Infrastructure/Civil Works	Building Construction																																																																															
3) Materials Engineer	Infrastructure/Civil Works	Building Construction																																																																															
4) Safety and Health Officer	Infrastructure/Civil Works	Building Construction																																																																															
5) Foreman	Infrastructure/Civil Works	Building Construction																																																																															
10.5	<p>The minimum major equipment requirements are the following:</p> <table border="1" style="width: 100%; border-collapse: collapse;"> <thead> <tr> <th style="text-align: left;">Equipment</th> <th style="text-align: left;">Capacity</th> <th style="text-align: left;">Number of Units</th> <th style="text-align: left;">Ownership</th> </tr> </thead> <tbody> <tr> <td>Air Compressor, w/ Jackhammer</td> <td>250 cfm</td> <td style="text-align: center;">1</td> <td>Owned/Leased</td> </tr> <tr> <td>Backhoe</td> <td>0.40 cu.m., 94 hp</td> <td style="text-align: center;">1</td> <td>Owned/Leased</td> </tr> <tr> <td>Concrete Cutter</td> <td>6.5 HP</td> <td style="text-align: center;">1</td> <td>Owned/Leased</td> </tr> <tr> <td>Concrete Mixer</td> <td>1 bagger</td> <td style="text-align: center;">2</td> <td>Owned/Leased</td> </tr> <tr> <td>Concrete Vibrator</td> <td>3.5 HP</td> <td style="text-align: center;">2</td> <td>Owned/Leased</td> </tr> <tr> <td>Concrete Buggy</td> <td>N/A</td> <td style="text-align: center;">4</td> <td>Owned/Leased</td> </tr> <tr> <td>Dump truck</td> <td>15.00 cu.m.</td> <td style="text-align: center;">1</td> <td>Owned/Leased</td> </tr> <tr> <td>Cut-off machine</td> <td>14" Disc Ø</td> <td style="text-align: center;">1</td> <td>Owned/Leased</td> </tr> <tr> <td>Oxy/acetylene cutting outfit</td> <td>N/A</td> <td style="text-align: center;">1</td> <td>Owned/Leased</td> </tr> <tr> <td>Pay loader, vibratory</td> <td>12.05T</td> <td style="text-align: center;">1</td> <td>Owned/Leased</td> </tr> <tr> <td>Road Grader, vibratory</td> <td>125 hp</td> <td style="text-align: center;">1</td> <td>Owned/Leased</td> </tr> <tr> <td>Road Roller, vibratory</td> <td>12.05T</td> <td style="text-align: center;">1</td> <td>Owned/Leased</td> </tr> <tr> <td>Water truck</td> <td>1,000 gal.</td> <td style="text-align: center;">1</td> <td>Owned/Leased</td> </tr> <tr> <td>Welding Genset, diesel driven</td> <td>400 amp.</td> <td style="text-align: center;">1</td> <td>Owned/Leased</td> </tr> <tr> <td>Generator Set</td> <td>8KVA</td> <td style="text-align: center;">1</td> <td>Owned/Leased</td> </tr> <tr> <td>Boom truck</td> <td>5T</td> <td style="text-align: center;">1</td> <td>Owned/Leased</td> </tr> <tr> <td>Diving outfit</td> <td>N/A</td> <td style="text-align: center;">2</td> <td>Owned/Leased</td> </tr> <tr> <td>Oxygen tank with fill</td> <td>N/A</td> <td style="text-align: center;">2</td> <td>Owned/Leased</td> </tr> <tr> <td>Trailer with tractor head</td> <td>N/A</td> <td style="text-align: center;">1</td> <td>Owned/Leased</td> </tr> </tbody> </table>	Equipment	Capacity	Number of Units	Ownership	Air Compressor, w/ Jackhammer	250 cfm	1	Owned/Leased	Backhoe	0.40 cu.m., 94 hp	1	Owned/Leased	Concrete Cutter	6.5 HP	1	Owned/Leased	Concrete Mixer	1 bagger	2	Owned/Leased	Concrete Vibrator	3.5 HP	2	Owned/Leased	Concrete Buggy	N/A	4	Owned/Leased	Dump truck	15.00 cu.m.	1	Owned/Leased	Cut-off machine	14" Disc Ø	1	Owned/Leased	Oxy/acetylene cutting outfit	N/A	1	Owned/Leased	Pay loader, vibratory	12.05T	1	Owned/Leased	Road Grader, vibratory	125 hp	1	Owned/Leased	Road Roller, vibratory	12.05T	1	Owned/Leased	Water truck	1,000 gal.	1	Owned/Leased	Welding Genset, diesel driven	400 amp.	1	Owned/Leased	Generator Set	8KVA	1	Owned/Leased	Boom truck	5T	1	Owned/Leased	Diving outfit	N/A	2	Owned/Leased	Oxygen tank with fill	N/A	2	Owned/Leased	Trailer with tractor head	N/A	1	Owned/Leased
Equipment	Capacity	Number of Units	Ownership																																																																														
Air Compressor, w/ Jackhammer	250 cfm	1	Owned/Leased																																																																														
Backhoe	0.40 cu.m., 94 hp	1	Owned/Leased																																																																														
Concrete Cutter	6.5 HP	1	Owned/Leased																																																																														
Concrete Mixer	1 bagger	2	Owned/Leased																																																																														
Concrete Vibrator	3.5 HP	2	Owned/Leased																																																																														
Concrete Buggy	N/A	4	Owned/Leased																																																																														
Dump truck	15.00 cu.m.	1	Owned/Leased																																																																														
Cut-off machine	14" Disc Ø	1	Owned/Leased																																																																														
Oxy/acetylene cutting outfit	N/A	1	Owned/Leased																																																																														
Pay loader, vibratory	12.05T	1	Owned/Leased																																																																														
Road Grader, vibratory	125 hp	1	Owned/Leased																																																																														
Road Roller, vibratory	12.05T	1	Owned/Leased																																																																														
Water truck	1,000 gal.	1	Owned/Leased																																																																														
Welding Genset, diesel driven	400 amp.	1	Owned/Leased																																																																														
Generator Set	8KVA	1	Owned/Leased																																																																														
Boom truck	5T	1	Owned/Leased																																																																														
Diving outfit	N/A	2	Owned/Leased																																																																														
Oxygen tank with fill	N/A	2	Owned/Leased																																																																														
Trailer with tractor head	N/A	1	Owned/Leased																																																																														
12	Value Engineering Clause: Not Allowed																																																																																
15.1	<p>The bid security shall be in the form of a Bid Securing Declaration OR any of the following forms and amounts:</p> <p>a. The amount of not less than Php 305,803.52, if bid security is in cash, cashier's/manager's check, bank draft/guarantee or irrevocable letter of credit;</p>																																																																																

	b. The amount of not less than Php 764,508.70 if bid security is in Surety Bond.
16	Each Bidder shall submit One (1) original and Four (4) copies of their Technical and Financial Bid, properly book-bound with hard/soft cover. Screw-bound, ring-bound and combo-bound documents are not acceptable.
19.2	Partial bid is not allowed
20	Other appropriate licenses and permits required: None
21	Additional contract documents relevant to the Project that may be required by existing laws and/or the Procuring Entity, such as construction schedule and S-curve, manpower schedule, construction methods, equipment utilization schedule, construction safety and health program approved by the DOLE, and other acceptable tools of project scheduling.



***Section IV.
General Conditions of
Contract***

1. Scope of Contract

This Contract shall include all such items, although not specifically mentioned, that can be reasonably inferred as being required for its completion as if such items were expressly mentioned herein. All the provisions of RA No. 9184 and its 2016 revised IRR, including the Generic Procurement Manual, and associated issuances, constitute the primary source for the terms and conditions of the Contract, and thus, applicable in contract implementation. Herein clauses shall serve as the secondary source for the terms and conditions of the Contract.

This is without prejudice to Sections 74.1 and 74.2 of the 2016 revised IRR of RA No. 9184 allowing the GPPB to amend the IRR, which shall be applied to all procurement activities, the advertisement, posting, or invitation of which were issued after the effectivity of the said amendment.

2. Sectional Completion of Works

If sectional completion is specified in the **Special Conditions of Contract (SCC)**, references in the Conditions of Contract to the Works, the Completion Date, and the Intended Completion Date shall apply to any Section of the Works (other than references to the Completion Date and Intended Completion Date for the whole of the Works).

3. Possession of Site

- 3.1 The Procuring Entity shall give possession of all or parts of the Site to the Contractor based on the schedule of delivery indicated in the **SCC**, which corresponds to the execution of the Works. If the Contractor suffers delay or incurs cost from failure on the part of the Procuring Entity to give possession in accordance with the terms of this clause, the Procuring Entity's Representative shall give the Contractor a Contract Time Extension and certify such sum as fair to cover the cost incurred, which sum shall be paid by Procuring Entity.
- 3.2 If possession of a portion is not given by the above date, the Procuring Entity will be deemed to have delayed the start of the relevant activities. The resulting adjustments in contract time to address such delay may be addressed through contract extension provided under Annex "E" of the 2016 revised IRR of RA No. 9184.

4. The Contractor's Obligations

The Contractor shall employ the key personnel named in the Schedule of Key Personnel indicating their designation, in accordance with **ITB Clause 10.3** and specified in the **BDS**, to carry out the supervision of the Works.

The Procuring Entity will approve any proposed replacement of key personnel only if their relevant qualifications and abilities are equal to or better than those of the personnel listed in the Schedule.

5. Performance Security

- 5.1. Within ten (10) calendar days from receipt of the Notice of Award from the Procuring Entity but in no case later than the signing of the contract by both parties, the successful Bidder shall furnish the performance security in any of the forms prescribed in Section 39 of the 2016 revised IRR.
- 5.2. The Contractor, by entering into the Contract with the Procuring Entity, acknowledges the right of the Procuring Entity to institute action pursuant to RA No. 3688 against any subcontractor be they an individual, firm, partnership, corporation, or association supplying the Contractor with labor, materials and/or equipment for the performance of this Contract.

6. Site Investigation Reports

The Contractor, in preparing the Bid, shall rely on any Site Investigation Reports referred to in the SCC supplemented by any information obtained by the Contractor.

7. Warranty

7.1. In case the Contractor fails to undertake the repair works under Section 62.2.2 of the 2016 revised IRR, the Procuring Entity shall forfeit its performance security, subject its property(ies) to attachment or garnishment proceedings, and perpetually disqualify it from participating in any public bidding. All payables of the GOP in his favor shall be offset to recover the costs.

7.2. The warranty against Structural Defects/Failures, except that occasioned on force majeure, shall cover the period from the date of issuance of the Certificate of Final Acceptance by the Procuring Entity. Specific duration of the warranty is found in the SCC.

8. Liability of the Contractor

Subject to additional provisions, if any, set forth in the SCC, the Contractor's liability under this Contract shall be as provided by the laws of the Republic of the Philippines.

If the Contractor is a joint venture, all partners to the joint venture shall be jointly and severally liable to the Procuring Entity.

9. Termination for Other Causes

Contract termination shall be initiated in case it is determined *prima facie* by the Procuring Entity that the Contractor has engaged, before, or during the implementation of the contract, in unlawful deeds and behaviors relative to contract acquisition and implementation, such as, but not limited to corrupt, fraudulent, collusive, coercive, and obstructive practices as stated in ITB Clause 4.

10. Dayworks

Subject to the guidelines on Variation Order in Annex "E" of the 2016 revised IRR of RA No. 9184, and if applicable as indicated in the SCC, the Dayworks rates in the Contractor's Bid shall be used for small additional amounts of work only when the Procuring Entity's Representative has given written instructions in advance for additional work to be paid for in that way.

11. Program of Work

11.1. The Contractor shall submit to the Procuring Entity's Representative for approval the said Program of Work showing the general methods, arrangements, order, and timing for all the activities in the Works. The submissions of the Program of Work are indicated in the SCC.

11.2. The Contractor shall submit to the Procuring Entity's Representative for approval an updated Program of Work at intervals no longer than the period stated in the SCC. If the Contractor does not submit an updated Program of Work within this period, the Procuring Entity's Representative may withhold the amount stated in the SCC from the next payment certificate and continue to withhold this amount until the next payment after the date on which the overdue Program of Work has been submitted.

12. Instructions, Inspections and Audits

The Contractor shall permit the GOP or the Procuring Entity to inspect the Contractor's accounts and records relating to the performance of the Contractor and to have them audited by auditors of the GOP or the Procuring Entity, as may be required.

13. Advance Payment

The Procuring Entity shall, upon a written request of the Contractor which shall be submitted as a Contract document, make an advance payment to the Contractor in an amount not exceeding fifteen percent (15%) of the total contract price, to be made in lump sum, or at the most two installments according to a schedule specified in the SCC, subject to the requirements in Annex "E" of the 2016 revised IRR of RA No. 9184.

14. Progress Payments

The Contractor may submit a request for payment for Work accomplished. Such requests for payment shall be verified and certified by the Procuring Entity's Representative/Project Engineer. Except as otherwise stipulated in the SCC, materials and equipment delivered on the site but not completely put in place shall not be included for payment.

15. Operating and Maintenance Manuals

- 15.1. If required, the Contractor will provide "as built" Drawings and/or operating and maintenance manuals as specified in the SCC.
- 15.2. If the Contractor does not provide the Drawings and/or manuals by the dates stated above, or they do not receive the Procuring Entity's Representative's approval, the Procuring Entity's Representative may withhold the amount stated in the SCC from payments due to the Contractor.



***Section V.
Special Conditions of
Contract***

Special Conditions of Contract

GCC Clause	
2	Sectional completion: None
4.1	<i>[Specify the schedule of delivery of the possession of the site to the Contractor, whether full or in part.]</i>
6.1	Performance bond from PPA-Accredited surety and insurance company.
6	The site investigation reports are: None
7.2	Semi-permanent structures: Five (5) years Buildings of types 1, 2, and 3 as classified under the National Building Code of the Philippines, concrete/asphalt roads, concrete river control, drainage, irrigation lined canals, river landing, deep wells, rock causeway, pedestrian overpass, and other similar semi-permanent structures
10	No dayworks are applicable to the contract.
11.1	The Contractor shall submit the Program of Work to the Procuring Entity's Representative within 15 days of delivery of the Notice of Award.
11.2	The amount to be withheld for late submission of an updated Program of Work is
13	No advance payments or mobilization fees shall, as a rule, be extended or paid to the winning bidder per DOTr memorandum dated July 10, 2018.
14	No further instruction
15.1	The date by which operating and maintenance manuals are required is The date by which "as built" drawings are required upon submission of Final Billing.
15.2	The amount to be withheld for failing to produce "as built" drawings and/or operating and maintenance manuals by the date required is

Section VI. Specifications

**REPAIR OF DAMAGED R.C. PIER, CONCRETE PAVEMENT APPROACH, SLOPE PROTECTION, BACK-UP AREA AND REMOVAL OF SUNKEN DERELICTS/LOGS
PORT OF RIZAL, BGY. PUNTABAJA, RIZAL, PALAWAN**

**REPAIR OF DAMAGED R.C. PIER, CONCRETE PAVEMENT APPROACH,
SLOPE PROTECTION, BACK-UP AREA AND REMOVAL OF SUNKEN
DERELICTS/LOGS**

PORT OF RIZAL, BGY. PUNTABAJA, RIZAL, PALAWAN

TECHNICAL SPECIFICATIONS

GENERAL REQUIREMENTS

1.0 MOBILIZATION & DEMOBILIZATION

1.1.1 GENERAL

Work under this Contract shall be in accordance with the terms and conditions stipulated in the Conditions of Contract and Section 1 "General Requirements" of these Specifications and shall apply to this Section whether herein referred to or not.

1.1.2 SCOPE OF WORK

This Section includes mobilization, demobilization, assembly and disassembly of equipment/plants including incidentals necessary to complete the work.

1.1.3 MOBILIZATION

a) The Contractor shall mobilize and put into operation all equipment and plants required to undertake the Contract.

b) Mobilization shall include the transferring to the job-sites of all equipment, plants, supplies and materials, personnel, and all items necessary for the execution and completion of the work, and shall also include the setting up of all equipment, instruments and all other plants until rendered operable, subject to the confirmation of the Engineer.

c) Sufficient supply of spares for the equipment and plants shall be carried on-site. Equipment/plants encountering breakdowns must be repaired on site by the most expeditious method possible at no cost to the Procuring Entity. In the event that the equipment/plants call for major repair works that cannot be undertaken at the site, the Contractor shall replace such equipment/plants with equal or better performance capacity at no additional mobilization costs to the Procuring Entity and the Contractor shall not be entitled to any time extension.

1.1.4 DEMOBILIZATION

Demobilization upon request of the Contractor and approved by the Engineer, shall include the following:

The dismantling, preparation and loading for removal and shipment of all Contractor's plant, equipment and personnel at each site after completion of the works.

2.0 CONSTRUCTION PHOTOGRAPHS

**REPAIR OF DAMAGED R.C. PIER, CONCRETE PAVEMENT APPROACH, SLOPE PROTECTION, BACK-UP AREA AND REMOVAL OF SUNKEN DERELICTS/LOGS
PORT OF RIZAL, BGY. PUNTABAJA, RIZAL, PALAWAN**

Provide record progress photographs taken at a fixed point and angle as, when and where directed by the Engineer at intervals of not more than ten (10) days. The photographs shall be sufficient in number and location to record the exact progress of works. The Contractor shall provide the Engineer all the photographs stored in CDs-properly labeled. This should be submitted to ESD – PMO Palawan, after the project completion. Billing photographs shall be in 4R size with corresponding billboard indicating the name of the project and location, bill number, item number, name of the person taking the photograph, date taken and the on-going activity.

3.0 RECORDS OF DAILY ACTIVITIES / EVENTS

The Contractor shall maintain a daily log describing the important events pertaining to the Works, the working hours, the number of laborers employed, effective operation time of equipment, overtime hours, delays due to meteorological and maritime conditions, weather condition, lack of labor, materials or equipment, progress made including instructions, notifications, issues and concerns and recommendations made by the Engineer.

4.0 AS-BUILT DRAWINGS AND FINAL CONSTRUCTION REPORT

Within thirty (30) calendar days after the issuance of the Taking Over Certificate, the Contractor shall prepare and as-built drawings and a final construction report as draft. And within thirty (30) calendar days after the issuance of the Taking Over Certificate, the Contractor shall submit the Final Construction Report and Final As-Built drawings.

5.0 SAFETY

The Contractor shall be responsible for the safety of its workers. Wearing of personal protective equipments (PPEs) shall be mandatory.

At the end of each day's work, the site shall be left in safe condition, so that no part is in danger of toppling, or falling or creating hazards to personnel or equipment.

The construction site shall be properly lighted at night. Warning signs shall be properly located for the safety of the port users.

Safety guidelines as stipulated in PPA Engineering Circular 01-2020 pertaining to the implementation of PPA projects during the COVID-19 public health emergency must be observed and implemented. The contractor shall provide and use thermal scanners and footbaths as part of the safety measures.

**REPAIR OF DAMAGED R.C. PIER, CONCRETE PAVEMENT APPROACH, SLOPE PROTECTION, BACK-UP AREA AND REMOVAL OF SUNKEN DERELICTS/LOGS
PORT OF RIZAL, BGY. PUNTABAJA, RIZAL, PALAWAN**

SITE WORKS

1.0 SURVEY AND LAYOUT

1.1 GENERAL

- a) Division 1, "General Requirements" of these Specifications shall apply to this Section whether herein referred to or not.
- b) Applicable requirements under Section 2.3, "Surveys, Soundings, Soil Investigations and Installation of Markers".

1.2 SCOPE OF WORK

This Section covers survey and layout work.

1.3 SURVEY AND SETTING OUT OF WORKS

- a) The Contractor together with the PPA Representative shall carry out the survey by means of traversing and leveling connected to the approved / established reference points.
- b) The stations shall be established in accordance with Sub-section 2.3.6.
- c) The Contractor shall establish at least three (3) permanent monuments and three benchmarks in the port area on locations approved by the Engineer that can serve conveniently as reference points of future construction.

2.0 DEMOLITION, EXCAVATION AND DISPOSAL WORK

2.1 DESCRIPTION

This section shall be applied to the demolition work of existing port structures as well as disposal of debris/unusable materials and storage of usable materials.

2.2 GENERAL PROVISIONS

- a. The Contractor shall be deemed to have satisfied himself of the site conditions, and to have included in his unit prices provision for all risks that may arise during or in connection with the work.

**REPAIR OF DAMAGED R.C. PIER, CONCRETE PAVEMENT APPROACH, SLOPE PROTECTION, BACK-UP AREA AND REMOVAL OF SUNKEN DERELICTS/LOGS
PORT OF RIZAL, BGY. PUNTABAJA, RIZAL, PALAWAN**

- b) The demolition work shall be carried out by approved methods and equipment such as concrete breakers, gas-cutters, hydraulic jacks, compressed air disintegrators, etc., however, no blasting shall be used unless approved in writing by the Engineer and after obtaining the written permission of the concerned Authorities.
- c) The Contractor shall provide suitable equipment, skilled labor and appropriate temporary works such as scaffoldings to ensure safety in his demolition works as well as in the adjacent area.
- d) The Contractor shall demolish all the structural members above the level on which the subsequent and permanent works under this Contract will begin. To this end, the temporary construction works such as excavation shall be conducted by the Contractor.
- e) Materials coming from the demolition works, except general earth, shall remain the property of the Procuring Entity, the designated part of which shall be stored by the Contractor at places specified by the PPA's authorized Representative.

2.3. DEMOLITION

2.3.1. R C. Pier

The Contractor shall carry out all demolition, as much as possible, to have minimum disturbance to adjoining structural members. As such, hydraulic breakers are not permitted.

Appropriate means should be introduced in order to minimize the deposition on demolished materials into the seabed.

2.4 DISPOSAL AND STORAGE

Prior to the commencement of the demolition work, the Engineer shall submit to the Contractor a list in which all the materials to be salvaged and overhauled, as property of the Procuring Entity and the location of their storage shall be described.

The Contractor shall separate materials to be salvaged from debris. Salvaged materials shall be loaded and transported by the Contractor from the project site and shall be unloaded to Port of Puerto Princesa for safekeeping.

The Contractor may dump debris on land areas but out of the site, which areas shall be procured and prepared at his own expense. In this case, safety measures shall be undertaken in the transporting, unloading, covering and others as requested by the Engineer.

2.5 CLEARING WORKS

The Contractor shall remove all construction debris, used and unused materials, equipment, temporary structures and barricades from the project site

**REPAIR OF DAMAGED R.C. PIER, CONCRETE PAVEMENT APPROACH, SLOPE PROTECTION, BACK-UP AREA AND REMOVAL OF SUNKEN DERELICTS/LOGS
PORT OF RIZAL, BGY. PUNTABAJA, RIZAL, PALAWAN**

SPECIFICATIONS

1.0 R.C. PIER, RETAINING WALL, CONCRETE SLOPE PROTECTION AND WAVE DEFLECTOR

1.1. MATERIAL REQUIREMENTS

1.1.1. Durability and Strength

For all concrete construction, be it reinforced or plain, concrete shall develop a minimum strength (f_c) of 25 MPa (3,500 psi).

1.1.2. Cement

Except when specifically approved by the Engineer, only one (1) brand of cement shall be used for any individual structure. In determining the approved mix, only Portland cement shall be used as the cementitious material.

- a) Portland Cement: ASTM C 150

Type I (for general use in construction)

1.1.3 Admixture (if necessary)

- a) Air Entraining Admixture shall not be used in all concrete mixture.
b) Admixture other than air entraining agent shall conform to ASTM C 494.
c) Admixture containing chloride ions, or other ions producing deleterious effect shall not be used.

1.1.4 Aggregates:

- a) Crushed Coarse Aggregate

Conforming to ASTM C 33 and having nominal sizes passing 38.0 mm to 19.0 mm, 19.0 mm to 9.5 mm to No. 4 sieve. The material shall be well graded between the limits indicated and individually stockpiled. It shall be the Contractor's responsibility to blend the materials to meet the gradation requirements for various types of concrete as specified herein.

**REPAIR OF DAMAGED R.C. PIER, CONCRETE PAVEMENT APPROACH, SLOPE PROTECTION, BACK-UP AREA AND REMOVAL OF SUNKEN DERELICTS/LOGS
PORT OF RIZAL, BGY. PUNTABAJA, RIZAL, PALAWAN**

Nominal sizes for combined gradation shall be as follows:

ASTM Sieves	Nominal Size of Coarse Aggregates			
	40 mm	25 mm	19 mm	10 mm
50.0 mm (2")	100	-	-	-
38.0 mm (1 ½")	95-100	-	-	-
31.8 mm (1 ¼")	-	100	-	-
25.0 mm (1")	-	90-100	100	-
19.0 mm (¾")	35-70	-	90-100	-
16.0 mm (5/8")	-	25-90	-	100
9.5 mm (3/8") No. 4	10-30	-	20-55	85-100
	0-5	0-10	0-10	0-20

b) Fine Aggregate

ASTM C 33 except for gradation which has been revised to meet local conditions unless otherwise required by the Engineer, grading of fine aggregate shall be as follows:

ASTM Sieves	% by Weight Passing
9.5 mm (3/8") No. 4	100
No. 8	90 - 100
No. 16	80 - 100
No. 30	50 - 90
No. 50	25 - 60
No. 100	10 - 30
	2 - 10

- 1) Grading of fine aggregates shall be reasonably uniform and fineness modulus thereof shall not vary more than 0.2 from that of the representative sample in which mix proportions of concrete are based.
- 2) Due care shall be taken to prevent segregation.

1.1.5 Water

**REPAIR OF DAMAGED R.C. PIER, CONCRETE PAVEMENT APPROACH, SLOPE PROTECTION, BACK-UP AREA AND REMOVAL OF SUNKEN DERELICTS/LOGS
PORT OF RIZAL, BGY. PUNTABAJA, RIZAL, PALAWAN**

The water used in concrete, mortar and grout shall be free from objectionable quantities of silt, organic matter, alkali, salts and other impurities. Sea water shall not be used at any time.

1.1.6 Curing Materials

- a) **Membrane Forming Curing Compound: ASTM C 309**

1.1.7 Reinforcement:

Steel reinforcement, other than Steel for Prestressing, used in Reinforced Concrete, shall conform ASTM as follows:

- **ASTM A 305**
- **ASTM Designation A615-Deformed Billet Steel Bars for Concrete Reinforcement. Minimum yield strength of 230 MPa (33,400 psi) for diameter of 6 mm to 10 mm and 276 MPa (40,000 psi) for diameter of 12 mm to 36 mm.**
- **Welded steel wire ASTM Designation A185, Fabric for Reinforcement of Concrete.**

All bar reinforcement shall have deformed surfaces except that 6 mm bars may be plain.

1.1.8 Tie Wire

Tie wire shall be plain, cold drawn annealed steel wire 1.6 mm diameter (Ga. 16).

1.2. FORMWORK

- a) **Forms: Designed, constructed, and maintained so as to insure that after removal of forms the finished concrete members will have true surfaces free of offset, waviness or bulges and will conform accurately to the indicated shapes, dimensions, lines, elevations and positions. Form surfaces that will be in contact with concrete shall be thoroughly cleaned before each use.**
- b) **Design: Studs and wales shall be spaced to prevent deflection of form material. Forms and joints shall be sufficiently tight to prevent leakage of**

**REPAIR OF DAMAGED R.C. PIER, CONCRETE PAVEMENT APPROACH, SLOPE PROTECTION, BACK-UP AREA AND REMOVAL OF SUNKEN DERELICTS/LOGS
PORT OF RIZAL, BGY. PUNTABAJA, RIZAL, PALAWAN**

grout and cement paste during placing of concrete. Juncture of formwork panels shall occur at vertical control joints, and construction joints. Forms placed on successive units for continuous surfaces shall be fitted in accurate alignment to assure smooth

completed surfaces free from irregularities and signs of discontinuity. Temporary opening shall be arranged to wall and where otherwise required to facilitate cleaning and inspection. Forms shall be readily removable without impact, shock, or damage to the concrete.

- c) **Form Ties:** Factory fabricated, adjustable to permit tightening of the forms, removable or snap-off metal of design that will not allow form deflection and will not spall concrete upon removal. Bolts and rods that are to be completely withdrawn shall be coated with a non-staining bond breaker. Ties shall be of the type which provide watertight concrete.
- d) **Coatings:** Forms for exposed surfaces shall be coated with form oil or form-release agent before reinforcement is placed. The coating shall be a commercial formulation of satisfactory and proven performance that will not bond with, stain, or adversely affect concrete surfaces, and shall not impair subsequent treatment of concrete surfaces depending upon bond or adhesion nor impede the wetting of surfaces to be cured with water or curing compounds. The coating shall be used as recommended in the manufacturer's printed or written instructions. Forms for unexposed surfaces may be wet with water in lieu of coating immediately before placing of concrete. Surplus coating on form surfaces and coating on reinforcement steel and construction joints shall be removed before placing concrete.
- e) **Removal of Forms** shall be done in a manner as to prevent injury to the concrete and to insure complete safety of the structure after the following conditions have been met. Where the structure as a whole is supported on shores, forms for beam and girder sides, and similar vertical structural members may be removed before expiration of curing period. Care shall be taken to avoid spalling the concrete surface or damaging concrete edges. Wood forms shall be completely removed.

Minimum stripping and striking time shall be as follows unless otherwise approved by the ENGINEER.

Vertical sides of beams, walls, and columns, lift not exceeding 1.2 m	12 hours
---	----------

**REPAIR OF DAMAGED R.C. PIER, CONCRETE PAVEMENT APPROACH, SLOPE PROTECTION, BACK-UP AREA AND REMOVAL OF SUNKEN DERELICTS/LOGS
PORT OF RIZAL, BGY. PUNTABAJA, RIZAL, PALAWAN**

Vertical sides of beams and walls, lift exceeding 1.2 m	36 hours
Soffits of main slabs and beams (props left under)	5 days
Removal of props from beams and main slabs and other work	10 days

1.3. REINFORCEMENT

- a) Reinforcement: Fabricated to shapes and dimensions shown and shall be placed where indicated. Reinforcement shall be free of loose or flaky rust and mill scale, or coating, and any other substance that would reduce or destroy the bond. Reinforcing steel reduced in section shall not be used. After any substantial delay in the work, previously placed reinforcing steel for future bonding shall be inspected and cleaned. Reinforcing steel shall not be bent or straightened in a manner injurious to the steel or concrete. Bars with kinks or bends not shown in the drawings shall not be placed. The use of heat to bend or straighten reinforcing steel shall not be permitted. Bars shall be moved as necessary to avoid interference with other reinforcing steel, conduits, or embedded items. If bars are moved more than one bar diameter, the resulting arrangement of bars including additional bars necessary to meet structural requirements shall be approved before concrete is placed. In slabs, beams and girders, reinforcing steel shall not be spliced at points of maximum stress unless otherwise indicated. Unless otherwise shown in the drawings, laps or splices shall be 40 times the reinforcing bar diameter
- b) The nominal dimensions and unit weights of bars shall be in accordance with the following table:

**REPAIR OF DAMAGED R.C. PIER, CONCRETE PAVEMENT APPROACH, SLOPE PROTECTION, BACK-UP AREA AND REMOVAL OF SUNKEN DERELICTS/LOGS
PORT OF RIZAL, BGY. PUNTABAJA, RIZAL, PALAWAN**

<u>Nominal Diameter</u> (mm)	<u>Nominal Perimeter</u> (mm)	<u>Nominal Sectional Area</u> (sq. mm)	<u>Unit Weight</u> (kg/m)
6	18.8	28.27	0.222
10	31.4	78.54	0.618
12	37.7	113.10	0.888
16	50.3	201.10	1.578
20	62.8	314.20	2.468
25	78.5	490.90	3.854
28	88.0	615.70	4.833
32	100.5	804.20	6.313
36	113.1	1017.60	7.991
40	125.7	1258.60	9.864
50	157.1	1963.50	15.413

- c) Welding of reinforcing bars shall only be permitted where shown; all welding shown shall be performed in accordance with AWS D 12.1.
- d) Exposed reinforcement bars, dowels and plates intended for bonding with future extensions shall be protected from corrosion.
- e) Supports shall be provided in conformance with ACI 315 and ACI 318, unless otherwise indicated or specified. f)

Concrete Protection for Reinforcement

- 1) The minimum concrete cover of reinforcement shall be as shown below unless otherwise indicated in the drawings.
- 2) Tolerance for Concrete Cover of Reinforcing Steel other than Tendons.

**REPAIR OF DAMAGED R.C. PIER, CONCRETE PAVEMENT APPROACH, SLOPE PROTECTION, BACK-UP AREA AND REMOVAL OF SUNKEN DERELICTS/LOGS
PORT OF RIZAL, BGY. PUNTAHAJA, RIZAL, PALAWAN**

Minimum Cover	Maximum Variation
7.5 cm or more (marine structures and concrete cast against and permanently exposed to earth)	9 mm
less than 7.5 cm (other structures)	6 mm

1.4. MIXING OF CONCRETE

a) General

- 1) Concrete shall be thoroughly mixed and placed in a mixer of an approved size and type that will insure a uniform distribution of the materials throughout the mass.
- 2) All concrete shall be mixed in mechanically operated mixers. The contractor should ensure that there is enough supply of concrete to complete the pouring of a section up to a construction joint that will meet the approval of the Engineer. As such, the contractor shall ensure the reliability of equipment to be used and the adequacy of materials on site whenever there is concrete pouring works.
- 3) Slump:
Tests shall be made in conformance with ASTM C 143, and unless otherwise specified by the Engineer, slump shall be within the following limits:

Structural Element	Slump for Vibrated Concrete	
	Minimum	Maximum
Pavement Concrete	25 mm	50 mm
Pre-cast Concrete	50 mm	70 mm
Lean Concrete	100 mm	200 mm
All other Concrete	50 mm	90 mm

- 11) Sampling: Provide suitable facilities and labor for obtaining representative samples of concrete for the Contractor's quality

**REPAIR OF DAMAGED R.C. PIER, CONCRETE PAVEMENT APPROACH, SLOPE PROTECTION, BACK-UP AREA AND REMOVAL OF SUNKEN DERELICTS/LOGS
PORT OF RIZAL, BGY. PUNTABAJA, RIZAL, PALAWAN**

control and the Engineer's quality assurance testing. All necessary platforms, tools and equipment for obtaining samples shall be furnished by the Contractor.

- c) Construction Joints: Unless otherwise specified herein, all construction joints shall be subject to approval of the Engineer. Concrete shall be placed continuously so that the unit will be monolithic in construction. Fresh concrete may be placed against adjoining units, provided the set concrete is sufficiently hard not to be injured thereby.

1.5. PREPARATION FOR PLACING

Hardened concrete, debris and foreign materials shall be removed from the interior of forms and from inner surfaces of mixing and conveying equipment. Reinforcement shall be secured in position, and shall be inspected, and approved before placing concrete. Runways shall be provided for wheeled concrete-handling equipment. Such equipment shall not be wheeled over reinforcement nor shall runways be supported on reinforcement.

1.6. PLACING CONCRETE

- a) Handling Concrete: Concrete shall be handled from mixers and transported to place for final deposit in a continuous manner, as rapidly as practicable, and without segregation or loss of ingredients until the approved unit of work is completed. Placing will not be permitted when the sun, heat, wind or limitations of facilities furnished by the Contractor prevent proper finishing and curing of the concrete. Concrete shall be placed in the forms, as close as possible in final position, in uniform approximately horizontal layers not over 40 cm deep. Forms splashed with concrete and reinforcement splashed with concrete or form coating shall be cleaned in advance of placing subsequent lifts. Concrete shall not be allowed to drop freely more than 1.5 m in unexposed work nor more than 1.0 m in exposed work; where greater drops are required, tremie or other approved means shall be employed. The discharge of the tremie shall be controlled so that the concrete may be effectively compacted into horizontal layers not more than 40 cm thick, and the spacing of the tremies shall be such that segregation does not occur. Concrete to be overlaid shall be screeded to the proper level to avoid excessive shimming or grouting. Conduits and pipes shall not be embedded in concrete unless specifically indicated.
- b) Time Interval between Mixing and Placing: Concrete mixed in stationary mixers and transported by non-agitating equipment shall be placed in the forms within 30 minutes from the time ingredients are charged into the

**REPAIR OF DAMAGED R.C. PIER, CONCRETE PAVEMENT APPROACH, SLOPE PROTECTION, BACK-UP AREA AND REMOVAL OF SUNKEN DERELICTS/LOGS
PORT OF RIZAL, BGY. PUNTABAJA, RIZAL, PALAWAN**

mixing drum. Concrete transported in truck mixers or truck agitators shall be delivered to the site of work, discharged in the forms within 45 minutes from the time ingredients are discharged into the mixing drum. Concrete shall be placed in the forms within 15 minutes after discharged from the mixer at the jobsite.

- 1) Cold Joints and Shrinkage: Where cold joints tend to form or where surfaces set and dry too rapidly or plastic shrinkage cracks tend to appear, concrete shall be kept moist by fog sprays, or other approved means, applied shortly after placement, and before finishing.
 - 2) Supplementary Precautions: When the aforementioned precautions are not sufficient to satisfy the requirements herein above, they shall be supplemented by restricting work during evening or night. Procedure shall conform to American Concrete Institute Standard ACI 305.
- c) Concrete Placing on Reinforced Concrete Pier

When placing concrete on wharf decks, the Contractor shall:

- Ensure that rate of placing is sufficient to complete proposed placing, finishing and curing operations within the scheduled time; that experienced finishing machine operators and concrete finishers are provided to finish the deck; that curing equipment and finishing tools and equipment are at the site of work and in satisfactory condition for use.
- Immediately prior to placing, the Contractor shall place scaffolding and wedges and make necessary adjustments. Care shall be taken to ensure that settlement and deflection due to added weight of concrete will be minimal. The Contractor shall provide suitable means to readily permit measurement of settlement deflection as it occurs.
- Should any event occur which, in opinion of the Engineer, would prevent the concrete conforming to specified requirements, the Contractor shall discontinue placing of concrete until corrective measures are provided satisfactory to the Engineer. If satisfactory measures are not provided prior to initial set of concrete in affected areas, the Contractor shall discontinue placing concrete and install a bulkhead at a location determined by the Engineer. Concrete in place beyond bulkheads shall be removed. The Contractor shall limit the size of casting to that which can be finished before beginning of initial set.

**REPAIR OF DAMAGED R.C. PIER, CONCRETE PAVEMENT APPROACH, SLOPE
PROTECTION, BACK-UP AREA AND REMOVAL OF SUNKEN DERELICTS/LOGS
PORT OF RIZAL, BGY. PUNTABAJA, RIZAL, PALAWAN**

1.7. COMPACTION

a) Immediately after placing, each layer of concrete shall be completed by internal concrete vibrators supplemented by hand-spading, rodding, and tamping. Tapping or other external vibration of forms will not be permitted unless specifically approved by the Engineer. Vibrators shall not be used to transport concrete inside the forms. Internal vibrators submerged in concrete shall maintain a speed of not less than 7,000 impulses per minute. The vibrating equipment shall at all times be adequate in number of units and power to properly consolidate all concrete.

b) Spare units shall be on hand as necessary to insure such adequacy.

The duration of vibrating equipment shall be limited to the time necessary to produce satisfactory consolidation without causing objectionable segregation. The vibrator shall not be inserted into the lower courses that have begun to set. Vibrator shall be applied vertically at uniformly spaced points not further apart than the visible effectiveness of the machine.

1.8. BONDING

Before depositing new concrete on or against concrete that has set, the surfaces of the set concrete shall be thoroughly cleaned so as to expose the coarse aggregate and be free of laitance, coatings, foreign matter and loose particles. Forms shall be re-tightened. The cleaned surfaces shall be moistened, but shall be without free water when concrete is placed.

1.9. FINISHES OF CONCRETE

Within 12 hours after the forms are removed, surface defects shall be remedied as specified herein. The Temperature of the concrete, ambient air and mortar during remedial work including curing shall be above 10°C. Fine and loose material shall be removed. Honeycomb, aggregate pockets, voids over 13 mm in diameter, and holes left by the rods or bolts shall be cut out to solid concrete, reamed, thoroughly wetted, brush-coated with neat cement grout, and filled with mortar. Mortar shall be a stiff mix of one part portland cement to not more than 2 parts fine aggregate passing the No. 16 mesh sieve, with a minimum amount of water. The color of the mortar shall match the adjoining concrete color. Mortar shall be thoroughly compacted in place. Holes passing entirely through walls shall be completely filled from the inside face by forcing mortar through the outside face. Holes which do not pass entirely through wall shall be packed full. Patchwork shall be finished flush and in the same plane as adjacent surfaces. Exposed patchwork shall be finished to match adjoining

**REPAIR OF DAMAGED R.C. PIER, CONCRETE PAVEMENT APPROACH, SLOPE PROTECTION, BACK-UP AREA AND REMOVAL OF SUNKEN DERELICTS/LOGS
PORT OF RIZAL, BGY. PUNTABAJA, RIZAL, PALAWAN**

surfaces in texture and color. Patchwork shall be damp-cured for 72 hours. Dusting of finish surfaces with dry material or adding water to concrete surfaces will not be permitted.

1.10. CONCRETE FINISHING DETAILS

- a) Deck surface shall be broom finish. The concrete shall be screeded and floated to required finish level with no coarse aggregate visible. After the surface moisture has disappeared and laitance has been removed, surface shall be float-finished to an even, smooth finish. The broom shall be drawn from edge to edge to the edge of the pavement perpendicular to the direction of traffic flow, with adjacent strokes slightly overlapping. The brooming operation should be so executed that the corrugations produced in the surface shall be uniform in appearance and not more than 1.5 mm in depth. Brooming shall be completed before the concrete is in such condition that the surface will be unduly roughened by the operation. The surface thus finished shall be free from rough and porous areas, irregularities, and depressions resulting from improper handling of the broom.

- d) Tolerance: Smooth and broom finished surfaces shall be true to plane with no deviation in excess of 3 mm in any direction when tested with a 3 m straight edge.

1.11. CURING

- a) Concrete shall be protected against moisture loss, rapid temperature changes, mechanical injury from rain or flowing water, for a minimum period of time given below:

Type B1 (piles/retaining walls/wharf/pier deck), and Type B2 (Concrete pavement for causeways and roads, stair landings and curbs	7 days
---	--------

- b) Concrete shall be maintained in a moist condition throughout the specified curing period. Curing activities shall be started as soon as free water has disappeared from the surface of the concrete after placing and finishing. Membrane forming compound shall be used. The compound shall be applied on damp surfaces as soon as the moisture film has disappeared. The curing compound shall be applied by power spraying using a spray nozzle equipped with a wind guard. The compound shall be applied in a two-coat, continuous operation at a coverage of not more than 10 sq m per liter for each coat. When application is made by hand sprayers the second coat shall be

**REPAIR OF DAMAGED R.C. PIER, CONCRETE PAVEMENT APPROACH, SLOPE PROTECTION, BACK-UP AREA AND REMOVAL OF SUNKEN DERELICTS/LOGS
PORT OF RIZAL, BGY. PUNTABAJA, RIZAL, PALAWAN**

applied in a direction approximately at right angles to the direction of the first coat. The compound shall form a uniform, continuous, adherent film that shall not check, crack, or peel and shall be free from pinholes or other imperfections. Surfaces subjected to rainfall within 3 hours after compound has been applied, or surfaces damaged by subsequent construction operations within the curing period, shall be immediately re-sprayed at the rate specified above. Surfaces coated with curing compound shall be kept free of foot and vehicular traffic, and from other causes of abrasion and contamination during the curing period.

1.12. TEST ON CONCRETE (COMPRESSIVE STRENGTH TEST)

All applicable tests and minimum incremental frequency of testing shall be as required by PPA MC 02-2016 (Revised Schedule of Minimum Test Requirements of Construction Materials for PPA Infrastructure Projects)

- a) For test purposes provide one (1) set of test specimen consisting of 3 cylinder samples taken from each day's pouring and to represent not more than 75 cu.m. of concrete or fraction thereof. Samples shall be secured in conformance with ASTM C 172. Tests specimens shall be made, cured, and packed for shipment in accordance with ASTM C 31. Cylinders will be tested by and at the expense of the Contractor in accordance with ASTM C 39. Test specimens will be evaluated separately by the Engineer, for meeting strength level requirements for each with concrete quality of ACI 318. Concrete should be tested at 14th day after sampling. When samples fail to conform to the requirements for strengths, the Engineer shall have the right to order a change in the proportions of the concrete mix for the remaining portions of the work at no additional cost to the Engineer.

- a) For proper identification, samples should be properly marked as to date of sampling and as to what part of the structure they represent. Photographs should be taken both at the time of sampling and testing.

2.0 BACK – UP AREA AND CAUSEWAY APPROACH

2.1 SUBGRADE PREPARATION

2.1.1 Description

The subgrade preparation shall be the part of the work which is the preparation for the support of the sub-base or, if there is no sub-base, the surfacing of the pavement structure. It shall extend to the full width of the road including the shoulders as shown in the drawings or as specified herein. Unless otherwise agreed by the Engineer subgrade preparation of a section of road shall not commence unless the Contractor is able, after the completion and acceptance of the work, to commence immediately pavement construction.

2.1.2 MATERIAL REQUIREMENTS

Unless otherwise stated in the Contract and except when the subgrade is in rock cut, all materials below subgrade level to a depth of 150 mm or to such greater depth as may be specified shall meet the requirements of selected borrow for topping, e.g., soil of such gradation that all particles will pass a sieve with 75 mm (3 inches) square openings and not more than 15 percent will pass the 0.075 mm (No. 200) sieve, as determined by AASHTO T 11. The material shall have a plasticity index of not more than 6 as determined by AASHTO T 90 and liquid limit of not more than 30 as determined by AASHTO T89.

2.1.3 EXECUTION

a) Prior Works

Prior to commencing the preparation of the subgrade all culverts, ditches, drains and drainage outlets shall be completed. No work shall be started on the preparation of the subgrade before the prior works are herein approved by the Engineer.

b) Where the new pavement is to be constructed immediately over an existing gravel surfaced pavement and if so specified in the Contract the pavement shall be scarified, thoroughly loosened, reshaped and recompactd in accordance with item c) below.

c) Unless otherwise ordered by the Engineer a variable load pneumatic tired roller shall be used to proof roll the subgrade. The roller shall have a load variable within the range of at least from 15 to 45 tons, on an overall width not greater than 3.2 m and shall have tires whose pressures are variable up to not less than 620 KN/sq.m. The wheels shall be in row and shall be capable of considerable vertical movement relative to each other without appreciable variation in loading either by each supporting a separate ballast unit, or by virtue of an efficient interconnecting

suspension system. The ballast shall be in a form which permits rapid adjustment of loads. The total loaded weight and tire pressure used at any time shall be as directed by the Engineer. The pneumatic tired roller shall not be towed over completed sub-bases or surfacings without the prior approval of the Engineer on each occasion. The proof rolling shall consist of one pass of the roller along the center of each lane of the traveled way.

The subgrade shall be compacted to a depth of 150 mm to the requirements of Table 5.6.1. This work shall comply with all the specified requirements for compaction of earthwork.

Table 5.6.1 Compaction Requirements

Soil Type Classification According to AASHTO M 145	Test Method for Determining Moisture Density Relations	Minimum Relative Density Field Dry Density as % of Maximum Dry Density as Determined by the Specified Test Method
<p>A - 1 A - 2 - 4 A - 2 - 5 A - 3</p>	<p>AASHTO T 180 (4.54 kg rammer) Method D</p>	<p>90%</p>
<p>A - 2 - 6 A - 2 - 7 A - 4 A - 5 A - 6 A - 7</p>	<p>AASHTO T 99 (4.54 kg rammer) Method D</p>	<p>95%</p>

d) Protection of Completed Work

Any part of the subgrade that has been completed shall be protected and any damage resulting from default of the Contractor shall be repaired as directed by the Engineer without additional payment.

The Contractor shall be responsible for all the consequences of traffic being admitted to the subgrade. He shall repair any ruts or ridges occasioned by his own traffic or that of others by reshaping and recompacting. He shall limit the amount of subgrade preparation to an area that can be maintained with the equipment available. He shall arrange for subgrade preparation and sub-base or base placing to follow each other closely. The subgrade, when prepared too soon in relation to the laying of the sub-base, is liable to deteriorate, and in such case the Contractor shall, without additional payment, repair, reroll, or recompact the subgrade as may be necessary restore it to the state specified herein.

2.2 AGGREGATE BASE COURSE

2.2.1 DESCRIPTION

This Section shall consist of furnishing, placing and compacting aggregate base course on a prepared subgrade in accordance with this Specification and the lines, grades, thickness and typical cross-sections shown on the Plans, or as established by the Engineer.

2.2.2 MATERIAL REQUIREMENTS

Aggregate for base course shall consist of hard, durable particles or fragments of crushed slag or crushed or natural gravel and filler of natural or crushed sand or other finely divided mineral matter. The composite material shall be free from vegetable matter and lumps or balls of clay, and shall be of such nature that it can be compacted readily to form a firm, stable base.

The base course material shall conform to Table

5.8.2.1:

Table 5.8.2.1 - Grading Requirements

Sieve Designation		Mass Percent Passing	
Standard mm	Alternate US Standard	Grading A	Grading B
50	2"	100	
37.5	1 1/2"	-	100
25.0	1"	60-85	
19.0	3/4"	-	60-85
12.5	1/2"	36-65	-
4.75	No. 4	20-50	30-55
0.425	No. 40	5-20	8-25
0.075	No. 200	0-12	2-14

The fraction passing the 0.075 mm (No.200) sieve shall not be greater than 0.66 (two thirds) of the fraction passing the 0.425 mm (No. 40) sieve.

The fraction passing the 0.425 mm (No.40) sieve shall have a liquid limit not greater than 25 and plasticity index not greater than 6 as determined by AASHTO T 89 and T 90, respectively.

2.2.3 EXECUTION

2.2.3.1 PREPARATION OF EXISTING SURFACE

The existing surface shall be graded and finished as provided under Section

5.6, "Subgrade Preparation", before placing the base material.

2.2.3.2 Placing

The aggregate base material shall be placed as a uniform mixture on a prepared subgrade in a quality which will provide the required compacted thickness. When more than one layer is required, each layer shall be shaped and compacted before the succeeding layer is placed.

The placing of materials shall begin at the point designated by the Engineer. Placing shall be from vehicles especially equipped to distribute the material in a continuous uniform layer or windrow. The layer or windrow shall be of such size that when spread and compacted the finished layer shall be in reasonably close conformity to the nominal thickness shown on the Plans.

When hauling is done over previously placed material, hauling equipment shall be dispersed uniformly over the entire surface of the previously constructed layer, to minimize rutting or uneven compaction.

2.2.3.3 Spreading and Compacting

When uniformly mixed, the mixture shall be spread to the plan thickness, for compaction. Where the required thickness is 150 mm or less, the material may be spread and compacted in one layer. Where the required thickness is more than 150 mm, the aggregate base shall be spread and compacted in two or more layers of approximately equal thickness, and the maximum compacted thickness of any one layer shall not exceed 150 mm. All subsequent layers shall be spread and compacted in a similar manner.

The moisture content of base material shall, if necessary, be adjusted prior to compaction by watering with approved sprinkler mounted on trucks or by drying out, as required in order to obtain the required compaction.

Immediately following final spreading and smoothing, each layer shall be compacted to the full width by means of approved compaction equipment. Rolling shall progress gradually from the sides to the center, parallel to the centerline of the road, and shall continue until the whole surface has been rolled. Any irregularities or depressions that develop shall be corrected by loosening the material at these places and adding or removing material until the surface is smooth and uniform. Along curbs, headers, and walls, and at all places not accessible to the roller, the base material shall be compacted thoroughly with approved tampers or compactors.

If the layer of base materials, or part thereof, does not conform to the required finish, the Contractor shall, at his own expense, make the necessary corrections.

2.3. CONCRETE PAVEMENT

All applicable tests and minimum incremental frequency of testing shall be as required by PPA MC 02-2016 (Revised Schedule of Minimum Test Requirements of Construction Materials for PPA Infrastructure Projects)

2.3.1 MATERIALS

a. *Cement*

Cement used shall be Type I Portland conforming to the requirements of the latest revision of ASTM C 150 "Standard Specifications for Portland Cement".

b. *Coarse Aggregates*

Coarse Aggregates shall be washed, well graded, hard pieces of gravel, crushed gravel or rock conforming to the requirements of ASTM C 33 "Standard Specification for Concrete Aggregates".

c. *Fine Aggregates*

Fine Aggregates shall be washed sand, stone screenings or other inert materials of same characteristics, or any combination thereof composed clean, hard, strong, uncoated grains and free from injurious amount of dust, lumps of clay, shale, alkali, and organic matter. It shall conform to the requirements of ASTM C33 "Standard Specifications for Concrete Aggregates". Beach sand shall not be used unless approved by the Engineer.

e. *Tie Bars and Dowels*

Tie bars for joints shall be deformed steel bars conforming to the requirements specified in AASHTO M 31 or equivalent sizes as indicated in the drawings or as approved by the Engineer. The deformed steel bars shall be grade 40. Dowel bars shall be plain steel bars conforming to the requirements specified in AASTHO M 31 or equivalent.

f. *Joint Filler*

Poured filler for joint shall conform to the requirements of AASTHO M173. The filler for each joint shall be furnished in single piece for the depth and width required for the joint unless otherwise authorized by the Engineer.

2.3.2 METHOD OF CONSTRUCTION

2.3.2.1 Sub-grade Preparation

The sub-grade shall be well compacted and leveled to the specified elevation prior to placing of base courses.

b. Protection of Completed Works

Any part of the sub-grade that has been completed shall be protected and any damaged resulting from the negligence on the part of the Contractor shall be repaired by him as directed by the Engineer without additional payment.

The sub-grade when prepared too soon in relation to the laying of the sub-base, is liable to deteriorate, and in such case, the Contractor shall, without additional payment, repair, re-roll or re-compact the sub-grade as may be necessary to restore it to the state specified herein.

2.3.2.2 Aggregate Sub-base Course and Aggregate Base Course

The aggregate sub-base and base course material shall be placed as a uniform mixture on a prepared sub-grade in a quantity which will provide the required compacted thickness.

2.3.2.3 Concrete Mix

a. Concrete Class

The concrete for pavement shall satisfy the following requirements:

Minimum Compressive strength	-	24 MPa / 3500 psi
Maximum Aggregate Size	-	38mm
Maximum Water Cement ratio	-	0.45

b. Proportioning, Consistency and Mixing of Concrete

The Engineer shall determine from laboratory tests of the materials to be used, the cement content and the proportions of aggregate and water that will produce workable concrete. The following table are the required slump

Structural Element	Slump for Vibrated Concrete	
	Minimum	Maximum
R.C. Deck and Beams	50 mm	90 mm
Concrete Pavement	25 mm	50 mm

c. Preparation

The base shall be watered and thoroughly moistened prior to the placing of the concrete to avoid premature concrete dehydration.

d. Formwork Construction

Forms shall be of steel, of an approved section and shall be straight and of a depth equal to the thickness of the pavement at the edge. The base of the forms shall be of sufficient width to provide the necessary stability in all directions. Protrusion should be provided at the midheight continuous along its length to provide side groove. These should be properly braced in order to avoid horizontal or vertical misalignment.

e. Joints

All joints, longitudinal, transverse, etc., shall be constructed as shown on the Drawings and shall be clean and free of all foreign material.

2.3.3 STORAGE OF MATERIALS

1.3.1 Cement shall, be stockpiled as closely as possible, in weatherproof storage sheds, stacks suitably elevated above ground to prevent cement absorption of moisture.

1.3.2 Aggregates shall be placed in stockpile in a manner preventing segregation thereof and contamination with foreign materials.

1.3.3 Reinforcing steel bars shall be stored properly, covered and protected from humidity to prevent rusting and contamination with oil, dirt or other objectionable matters

2.3.4 DESIGNED STRENGTH OF CONCRETE

Concrete shall develop compressive cylinder strength (f_c) of 3,500 psi (25 MPa), unless otherwise indicated in the drawings.

2.3.5 MIXING OF CONCRETE

1. Concrete mix shall be machine-mixed at the designated site. Each batch shall be mixed at the mixer's design speed.
2. All mixed contents of the mixer shall be thoroughly removed before any succeeding batch is placed.
3. The materials for the first batch shall contain sufficiently excess cement, sand, and water to coat the inside walls of the mixer without reducing the required mortar content of the mix. The mixer shall be provided with devices for accurately measuring and controlling the amount of water used in each batch and for automatically recording the number of revolutions of the mixer.

2.3.6 PLACING OF CONCRETE

a) Concrete shall be placed in the presence of the Engineer only after the forms, reinforcing bars and other spaces to receive the concrete have been inspected and approved by him.

b) Concrete shall be placed only when wind and weather conditions will allow proper placement and curing of the concrete. Notice of any concreting operations shall be served to the Engineer at least three (3) days ahead of each schedule.

c) Mixed concrete shall be deposited in its final position within a practicable time. Each succeeding fresh deposit for particular structural member shall be placed at a practicable rate to prevent cold joints. Each successive fresh deposit of concrete shall be vibrated vertically at uniformly spaced points and levels, of such duration and intensity to compact the concrete

thoroughly but shall be discontinued the moment segregation of materials is noticed.

d) Where concreting operations involve a fall more than 1.50 meters (4.92 feet), the fresh concrete shall be poured through approved sheet metal conduit or pipes. The pipes shall be kept full of concrete and its lower end kept below the surface of concrete throughout, the, pouring operations.

e) Deposition of concrete shall be in such a way as to prevent segregation of the materials and the displacement of the reinforcement. Placing shall be done preferably with the use of buggies, buckets or wheel-borrows. Troughs, conveyors and pipes and the manner of use of each one shall be with the expressed permission of the Engineer.

f) Each layer of concrete shall be placed approximately normal as possible in uniform layers not exceeding 0.30 meter, unless otherwise ordered. The rate of placing concrete in the forms shall preferably be 0.025 meter (0.082 feet) vertical rise per minute.

2.3.7 CURING AND WATER PROOFING

All concrete shall be cured for at least 7 days after the date of placing in accordance with the approved and accepted methods.

2.3.8 FINISHING OF CONCRETE SURFACES

Surface shall be broom finish. It shall conform accurately to the form, alignment, grades and sections shown in the drawings or as prescribed by the Engineer. It shall be free from bulges, ridges, honeycombing or roughness of any kind and shall be of a reasonably smooth wood float finish. Maximum tolerance for surface imperfection is 3mm for 3m straight edge.

2.3.9 REINFORCING STEEL

It shall conform to the requirements of Item 404, Reinforcing Steel. Dowels and tie bars shall conform to the requirements of AASHTO M 31 or M 42, except that rail steel shall not be used for tie bars that are to be bent and restraightened during construction. Tie bars shall be deformed bars. Dowels shall be plain round bars.

2.3.10 JOINTS

Joints shall be constructed of the type and dimensions, and at the locations required by the Plans or Special Provisions. All joints shall be protected from the intrusion of injurious foreign material until sealed.

2.3.10.1 Longitudinal Joint

Deformed steel tie bars of specified length, size, spacing and materials shall be placed perpendicular to the longitudinal joints, they shall be placed by approved mechanical equipment or rigidly secured by chair or other approved supports to prevent displacement. Tie bars shall not be painted or coated with asphalt or other materials or enclosed

in tubes or sleeves. When shown on the Plans and when adjacent lanes of pavement are constructed separately, steel side forms shall be used which will form a keyway along the construction joint. Tie bars, except those made of rail steel, may be bent at right angles against the form of the first lane constructed and straightened into final position before the concrete of the adjacent lane is placed. In lieu of bent tie bars, approved two-piece connectors may be used.

Longitudinal formed joints shall consist of a groove or cleft, extending downward from and normal to the surface of the pavement. These joints shall be effected or formed by an approved mechanically or manually operated device to the dimensions and line indicated on the Plans while the concrete is in a plastic state. The groove or cleft shall be filled with either a premolded strip or poured material as required.

The longitudinal joints shall be continuous. There shall be no gaps in either transverse or longitudinal joints at the intersection of the joints.

Longitudinal sawed joints shall be cut by means of approved concrete saws to the depth, width and line shown on the Plans. Suitable guide lines or devices shall be used to assure cutting the longitudinal joint on the true line. The longitudinal joint shall be sawed before the end of the curing period or shortly thereafter and before any equipment or vehicles are allowed on the pavement. The sawed area shall be thoroughly cleaned and, if required, the joint shall immediately be filled with sealer.

Longitudinal pavement insert type joints shall be formed by placing a continuous strip of plastic materials which will not react adversely with the chemical constituent of the concrete.

2.3.10.2 Transverse Contraction Joint/Weakened Joint

When shown on the Plans, it shall consist of planes of weakness created by forming or cutting grooves in the surface of the pavement and shall include load transfer assemblies. The depth of the weakened plane joint should at all times not be less than 50 mm, while the width should not be more than 6 mm.

Sawed Contraction Joint. It shall be created by sawing grooves in the surface of the pavement of the width not more than 6 mm, depth should at all times not be less than 50 mm, and at the spacing and lines shown on the Plans, with an approved concrete saw. After each joint is sawed, it shall be thoroughly cleaned including the adjacent concrete surface.

Sawing of the joint shall commence as soon as the concrete has hardened sufficiently to permit sawing without excessive raveling, usually 4 to 24 hours. All joints shall be sawed before uncontrolled shrinkage cracking takes place. If necessary, the sawing operations shall be carried on during the day or night, regardless of weather conditions. The sawing of any joint shall be omitted if crack occurs at or near the joint location prior to the time of sawing. Sawing shall be discontinued when a crack

develops ahead of the saw. In general, all joints should be sawed in sequence.

2.3.10.3 Transverse Construction Joint

It shall be constructed when there is an interruption of more than 30 minutes in the concreting operations. No transverse joint shall be constructed within 1.50 m of an expansion joint, contraction joint, or plane of weakness. If sufficient concrete has been mixed at the time of interruption to form a slab of at least 1.5 m long, the excess concrete from the last preceding joint shall be removed and disposed off as directed.

2.3.11 TEST ON CONCRETE (FLEXURAL STRENGTH TEST)

Test on concrete shall be in accordance with the following:

As work progresses, at least one (1) set consisting of three (3) concrete beam test specimens, 150 mm x 150 mm x 525 mm shall be taken from each 330 m² of pavement, 250 mm depth, or fraction thereof placed each day. Test specimens shall be made under the supervision of the Engineer, and the Contractor shall provide all concrete and other facilities necessary in making the test specimens and shall protect them from damage by construction operations. Cylinder samples shall not be used as substitute for determining the adequacy of the strength of concrete.

The beams shall be made, cured, and tested in accordance with AASHTO T 23 and T 97.

Samples shall be taken by the Contractor under the supervision of the Engineer; and shall be delivered as soon as practicable for testing, at his expense, to the designated laboratories.

The samples should be properly marked to identify the date of sampling as well as the part / location of the pavement in which they are sampled. Photographs shall also be taken both at the time of sampling and testing.

The flexural strength of concrete should not be less than 550 psi (3.80 MPa)

3.0 MOORING AND FENDER SYSTEMS

3.1 GENERAL

3.1.2 SCOPE OF WORK

1. The work includes furnishing of all labor, materials and equipment to complete the installation of mooring bollards.
2. Work shall include the supply, transport, handling, storage and installation of fender systems in the newly repaired pier.
3. The Contractor shall furnish and install the necessary fittings for a complete job as shown on the drawings and/ or as specified. Supplementary parts necessary to complete and install each item of works shall be included whether or not shown or specified. The Contractor shall

furnish to relevant trades all anchors, fastenings, inserts, fittings, fixtures or the like to be installed on or required for securing the works. The Contractor shall submit shop drawings of all fitting works prior to placing orders and commencement of any fabrication.

3.1.3 MOORING SYSTEM

1. Designated load capacity of mooring bollards shall be as shown on the drawings, and shall refer to the safe working load. For this project, 25T T-head mooring bollard shall be installed. The bollards shall be capable of withstanding a proof test load of 1.5 times the safe working load.
2. Bollards at the new berth shall be installed at the edge of concrete decks of piers.

3.1.4 FENDERING SYSTEM

1. Material for fender systems such as rubber fenders, anchor bolts and templates shall be supplied by the Contractor.
2. The Contractor shall install the fender system properly according to the drawings and the instructions prepared by the Engineer.
3. Performance Requirements

The fenders shall be procured in accordance with the performance characteristics, under 52.50% fender deflection, specified hereunder:

Type of Fender	Min. Energy Absorption (Ton-M), min.	Max. Reaction Force (Ton), max.
V400 x 1000	4.78	28.64

4. Manufacturing Rubber Main Body

Rubber fenders shall be manufactured at the factories of approved makers.

Basic manufacturing methods shall be as follows:

- Shape of rubber main body: V-type
- Shape shall be V-shaped with internal hollow space
- Fabrication of rubber main body shall be completed at the factory
- No connection of main body shall be permitted out of the factory

- Steel plate shall be embedded in the deck sides of rubber main body.
- The Contractor shall submit manufacturer's methods of manufacturing for approval by the Engineer.

3.1.5 MATERIAL REQUIREMENTS

3.1.5.1 MOORING SYSTEM

- a) Mooring bollards shall be of the dimensions, weight, capacities and design in accordance with shop drawing approved by the Engineer and shall be fabricated by approved manufacturers with cast steel conforming to the following requirements or approved equivalent.
- b) The size of the bolts, nuts and washers shall be in accordance with the specifications of the manufacturer. However, the length of the bolts shall be as indicated on the drawings. The anchor plate shall be connected the holding down bolt with 12.5 mm weld, as show on the drawings. All bolts, nuts, washers, etc. that are exposed shall be galvanized to the satisfaction of the Engineer. Provide lead cover for exposed threads of galvanized anchor bolts. Samples of the bolts, nuts, washers and anchor plates shall be submitted to the Engineer for approval before being used in the works.
- c) The upper parts of bollards, bitts, and cleats not embedded in concrete shall be painted. The surface of bollards and bitts shall be cleaned thoroughly by wire brush or other means prior to painting to remove rust or any other contamination which may interfere with bond of paint to metal. The exposed surface shall be which may interfere with bond of paint to metal. The exposed surface shall be coated with rust proof paint and finishing paint, which shall be coal-tar epoxy of 120 micron thickness in accordance with JIS K5623 or the approved standard.
- d) **Alternative**
The Contractor can submit to the Engineer's approval bollards different from these specifications but with the capacities indicated in the drawings.
- e) **Concrete foundations/base of bollards shall conform to the requirements of Section 6, "Concrete Works."**
- f) **Visual Inspection**
All bollards delivered to site shall be inspected by the Engineer for any signs of flaws or defects inimical to usage.
- g) **Mill Test Certificates**
Two (2) copies of mill test reports shall be submitted certifying that materials meet the specified standards.
- h) **Tests and Inspection**
Inspection of all materials and methods of fabrication shall be carried out by the Contractor. However, the Engineer reserves the right to inspect

all facilities at any time during the manufacture to ensure that the materials and workmanship are in accordance with the specifications and the best workmanship.

3.1.5.2 RUBBER FENDER SYSTEM

1. Concrete with reinforcing bars on which the fenders are fixed shall conform to the requirements of Section 6, "Concrete Works."

2. Physical Properties

Material for rubber fenders will be one of the international accepted materials. Test methods shall conform to JIS K6301 or equivalent. The rubber material used for rubber fenders shall be a compound of natural rubber and synthetic rubber of high quality having sufficient resilience, anti – aging, weather and wear resistant property according to the following table.

3. Anchor

Anchor Bolts and connecting hardware shall be fabricated from type SUS 304 stainless steel to the required shapes and sized as shown on the approved shop drawings, and conforming to JIS G 4303 or equivalent.

4. Testing

The Contractor shall be required to submit test certificates showing compliance to the above requirements. The test certificates should be certified by an independent inspection organization recommended by the Contractor and approved by the Engineer. All fenders shall be tested for performance. The fender shall be compressed repeatedly three times to the minimum deflection at speed from 2 to 8 cm. per minute.

The load and deflection values shall be recorded with a precision of 0.5 mm. The results shall be plotted in the form of load-deflection-energy absorption curves. The average data obtained in the second and third test loadings shall be considered as performance values. The tests and reporting shall be carried by an approved laboratory and shall be supervised and certified by the independent inspection organization.

5. Sampling of Specimen

The specimens of rubber shall be taken at the mixing stage directly from each batch of rubber compound from manufacturing of fenders. The specimens shall be tested for compliance with requirements as specified in paragraph b of this Subsection.

6. Inspection for Dimension

- a. The fenders shall be inspected by the independent inspection organization. One fender out of five fenders of each type shall be inspected for compliance with dimensions. Five percent (5%) of anchor bolts and fittings shall be selected at random and inspected. Material for bolts and fittings to be covered by certified organization.

- b. Anchoring Bolt Holes in Fender

Diameter of the Hole Pitch of the Hole Tolerance +2 mm + 4 mm

- c. Performance requirements shall conform to paragraph c of Subsection 3.13.1.3 As basis for acceptance of all finished fenders supplied, a tolerance of + 10% on the performance requirements indicated will be acceptable. The cost of tests and inspection required herein are all for the Contractor's account.

7. Marking

All fender units shall be clearly numbered and marked. Markings shall be debossed to the rubber fender plate. Each fender shall have the following marking:

- a. Fender type and manufacturer's name or trademark
- b. Production serial number
- c. Date of manufacturing
- d. Main dimension (length, height)
- e. Name of Project

B. Warranty

The Contractor shall guarantee the fenders against any defects that are attributable to faulty design and manufacture and shall also guarantee the performance of the fenders under normal working conditions. The guarantee shall be for a minimum period of 12 months from the date of the issuance of Taking-Over Certificate of the Works.

During the period of guarantee, repairs and replacement of defective fender units and/ or material shall be carried by the Contractor at his own cost.

4.0 ROCKWORKS

4.1. GENERAL

Work under this Contract shall be in accordance with Division 1, "General Requirements" and shall apply to this Section, whether herein referred to or not.

4.1.1 SCOPE OF WORK

This Specification covers the construction of all revetments for the Project. The works to be carried out shall be, but not limited to the following:

1. Supply and laying of core rocks as shown in the drawings.
2. Supply and laying of secondary rocks as shown in the drawings.

4.1.2 MATERIAL REQUIREMENTS

3. The weight of individual pieces may exceed the maximum specified in the drawings by up to 25 percent.
4. Rock works shall be in accordance with Section 3.4, "Causeway."

4.1.3 EXECUTION

1. Core rocks shall be placed as uniformly as possible by controlled dumping or by other means acceptable to the Engineer.
2. Secondary rocks where required or as indicated in the Drawings shall be placed individually by means acceptable to the Engineer.

3. Permissible

Tolerance

a. Core Rock:

Alignment	plus or minus 0.30 m
Elevation	plus 0.20m

b. Secondary Rock:

Alignment	plus or minus 0.30 m
Elevation	plus 0.20m

4.1.4 QUARRY SITE AND ROCK QUANTITY

1. It is the Contractor's responsibility to make necessary surveys / investigations on quarry sites applicable to the Works, taking into consideration the nature of the rock works required under the Contract such as required quality, total quantity and daily required quantity, transportation method and route etc.,
2. The Contractor shall submit data on characteristics of proposed quarry sites together with the location of sites, test results of their products and samples for the approval of the Engineer.
3. When the Contractor intends to operate a quarry for the Works, the Contractor shall take all the responsibilities in connection with its operation including, but not limited to, obtaining all necessary permits and approvals, payment of safety measures or like (if any), provisions and maintenance of safety measures and temporary access roads, all of private

and public roads and temporary jetties to be used to transport quarried materials and the compliance with all regulations etc. required by the authorities having jurisdiction over any part of the operation.

Should any explosive be used in the quarry operations, the Contractor shall be responsible to meet laws and regulations, wherever applicable, established by the Local Government and Central Government Department concerned.

4. Despite the Engineer's previous approval of the natural rock and borrow pits, the Engineer reserves the right to suspend any operation in connection with the rock, if, in its opinion, such rock is not suitable for the work. In such case, the Contractor shall comply with the Engineer's instructions.

4.1.5 MEASUREMENT AND PAYMENT

1. Quantities of core rock, rubble, secondary rock, armour rock and rock fragments to be paid for shall each be measured in cubic meters. The volumes to be paid for shall be measured by taking cross-sections of the sea bed on the site of work at 10 meter intervals or closer, if necessary, immediately before placing the rock. The volumes of the different classes of rock shall then be computed based on the neat lines and elevations shown on the drawings and on the foregoing data, with probable settlement as shown in the drawings.
2. Unless otherwise directed by the Engineer, measurement for settlement shall be done by providing a 28mm diameter x 6.0m round bar calibrated rod attached or welded to the center of a one (1) x one (1) m steel plate at 6mm thick. Measuring device shall be installed at 20.0m interval prior to laying of 1st stage rock.

5.0 REMOVAL OF SUNKEN DERELICTS

5.1 SCOPE OF WORK

This Specification covers the removal of sunken logs / derelicts within the 50 meter radius measured from the center of the tip of the pier. All sunken obstructions must be removed from the seabed and placed at a designated area within the port premises.



Section VII. ***Drawings***

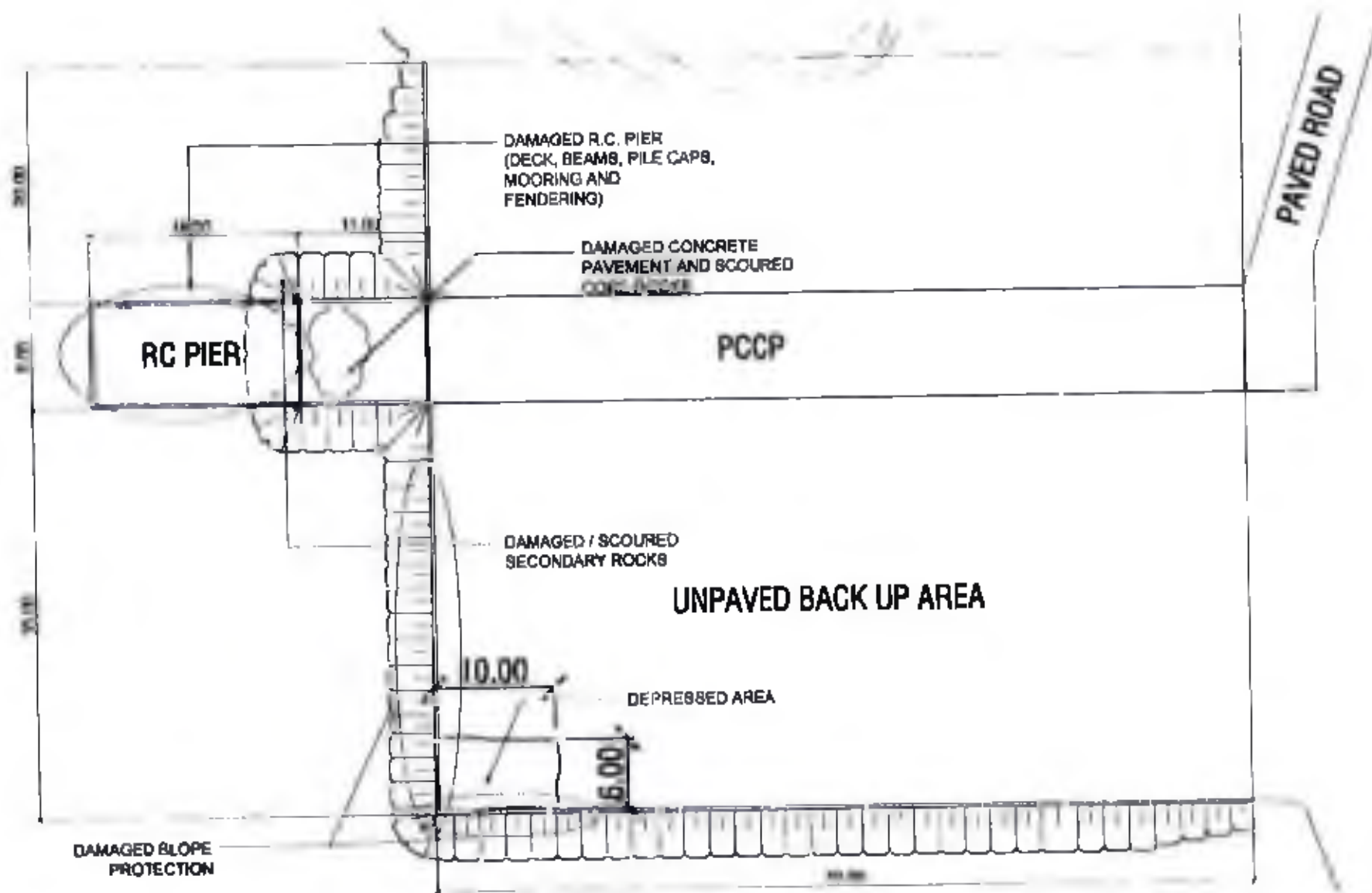

EXISTING PORT LAY OUT PLAN
PORT OF RIZAL, PUNTABAJA, RIZAL, PALAWAN

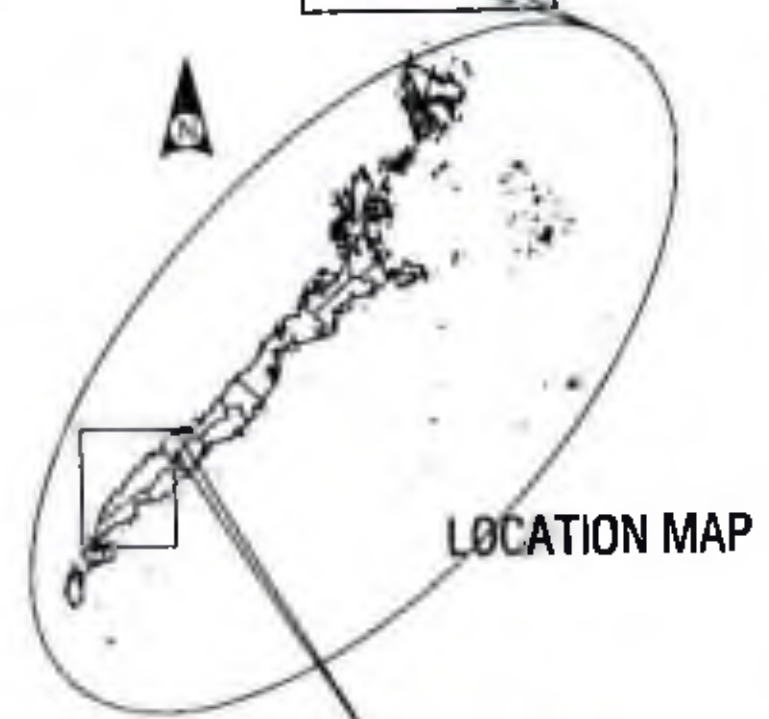

THIS SITE

	PROJECT TITLE AND LOCATION: REPAIR OF DAMAGED R.C. PIER, CONCRETE PAVEMENT APPROACH, SLOPE PROTECTION, BACK UP AREA AND REMOVAL OF SUNKEN DERELICTS/LOGS BGY. PUNTABAJA, RIZAL, PALAWAN	 RELY W. MADARCOS SENIOR ENGINEER A	 WILSON N. BENDAY DIEGO SENIOR ENGINEER B	 ELIZALDE M. ULSON ACTING PORT MANAGER	SHEET NO. / DATE 	SHEET NO. C-1 01/12
	FILE NAME: RIZAL PORT REPAIR 2021					

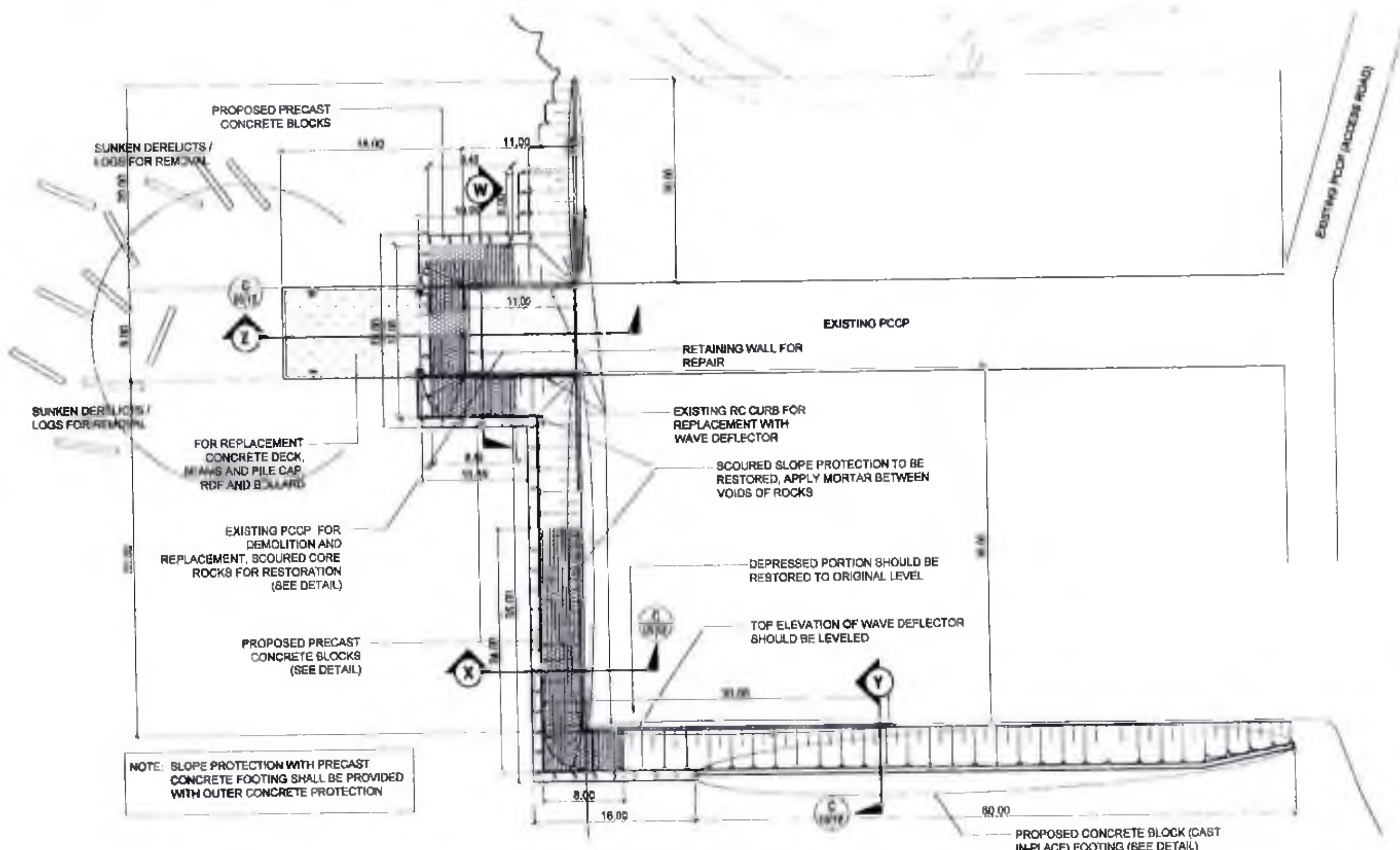

LAYOUT OF PROPOSED REPAIR WORKS

SCALE 1:400 METERS

 <p>PHILIPPINE PORTS AUTHORITY</p>	<p>PROJECT TITLE AND LOCATION: REPAIR OF DAMAGED R.C. PIER, CONCRETE PAVEMENT APPROACH, SLOPE PROTECTION, BACK UP AREA AND REMOVAL OF SUNKEN DERELICTS/LOGS BGY. BUNTABAJA, RIZAL, PALAWAN</p>	<p>DESIGNED BY:  RELY W. MADARCOS SENIOR ENGINEER A</p>	<p>RECOMMENDED BY:  ARLON N. SEMBRANO ESD MANAGER</p>	<p>APPROVED BY:  ELWALDE M. ULSOW ACTING PORT MANAGER</p>	<p>SHEET CONTENTS</p> <p>FILE NAME : RIZAL PORT REPAIR 2021</p> <p>C-1 02/12</p>
---	--	--	--	--	--

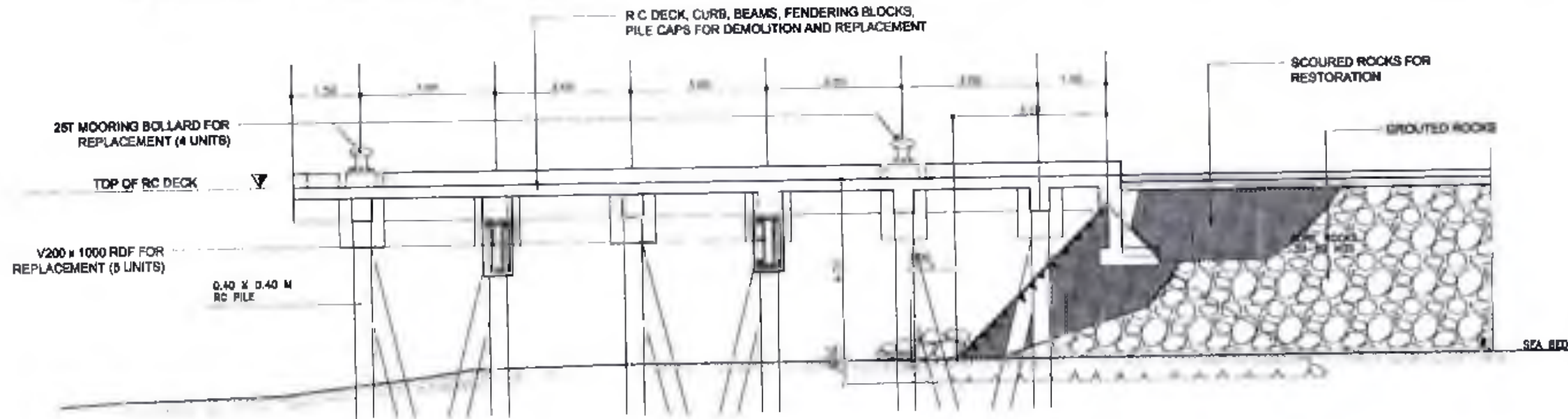

LONGITUDINAL ELEVATION (EXISTING)
SCALE 1:100 METERS

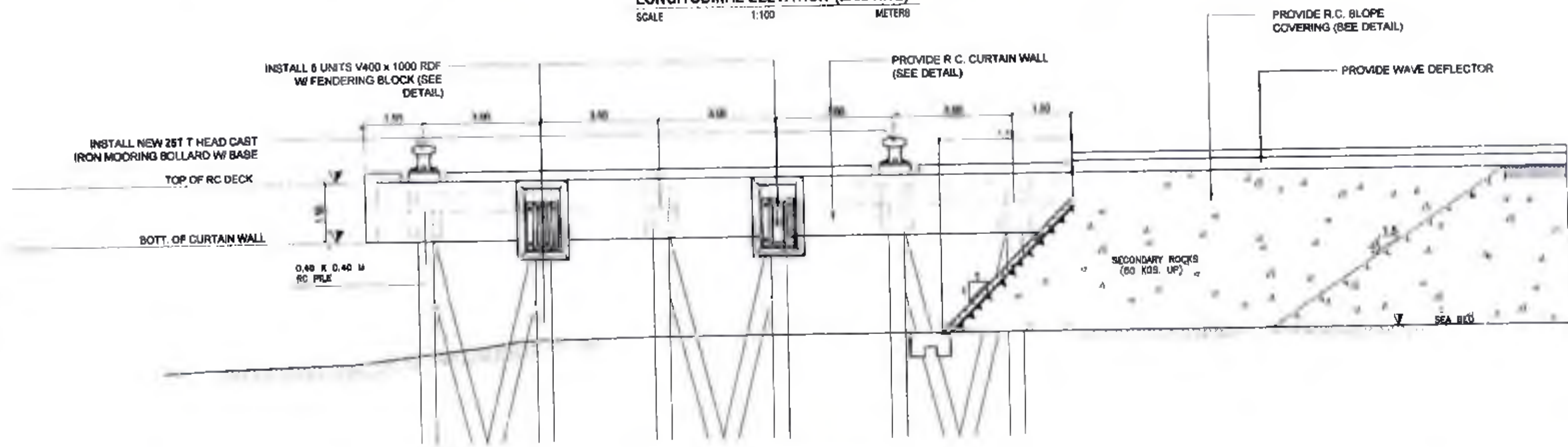

LONGITUDINAL ELEVATION (PROPOSED)
SCALE 1:100 METERS

<p>PHILIPPINE PORTS AUTHORITY</p>	<p>PROJECT TITLE AND LOCATION</p> <p>REPAIR OF DAMAGED R.C. PIER, CONCRETE PAVEMENT APPROACH, SLOPE PROTECTION, BACK UP AREA AND REMOVAL OF SUNKEN DERELICTS/LOGS</p> <p>BGY, PUNTABAJA, RIZAL, PALAWAN</p>	<p>DRAWN/PREPARED BY:</p> <p><i>[Signature]</i></p> <p>RELLY M. MADARCOS SENIOR ENGINEER A</p>	<p>APPROVED BY:</p> <p><i>[Signature]</i></p> <p>ARLON N. SERRAVALLO MANAGER</p>	<p>APPROVED BY:</p> <p><i>[Signature]</i></p> <p>ELIZALDE M. ULSON PORT MANAGER</p>	<p>FILE NAME: RIZAL PORT REPAIR 2021</p>	<p>C-1 03/12</p>
	<p>PHILIPPINE PORTS AUTHORITY - RIZAL PORT REPAIR 2021</p>					

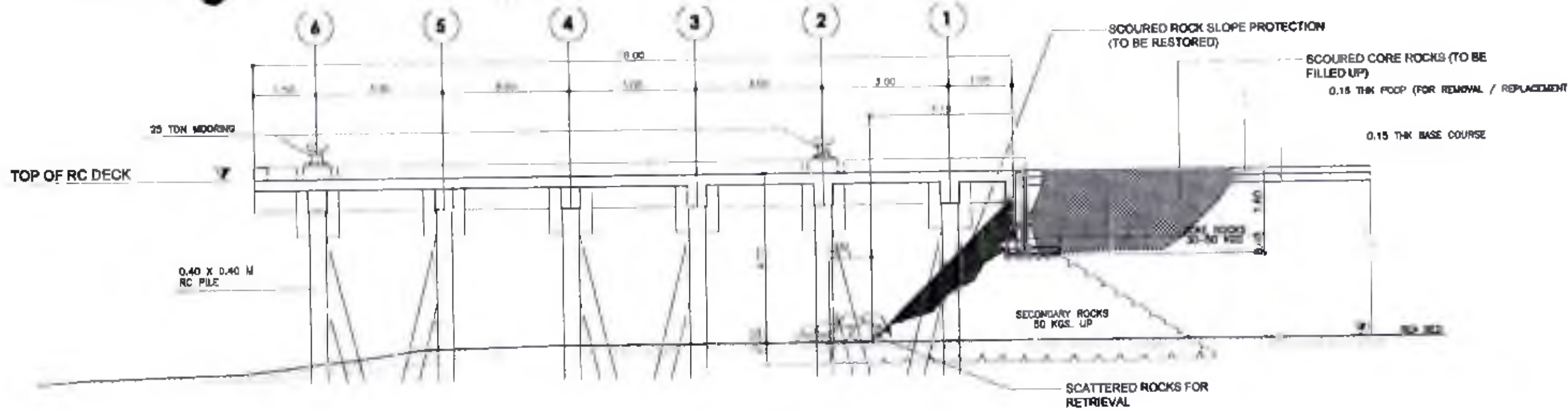

LONGITUDINAL SECTION (EXISTING)
SCALE 1/100 METERS

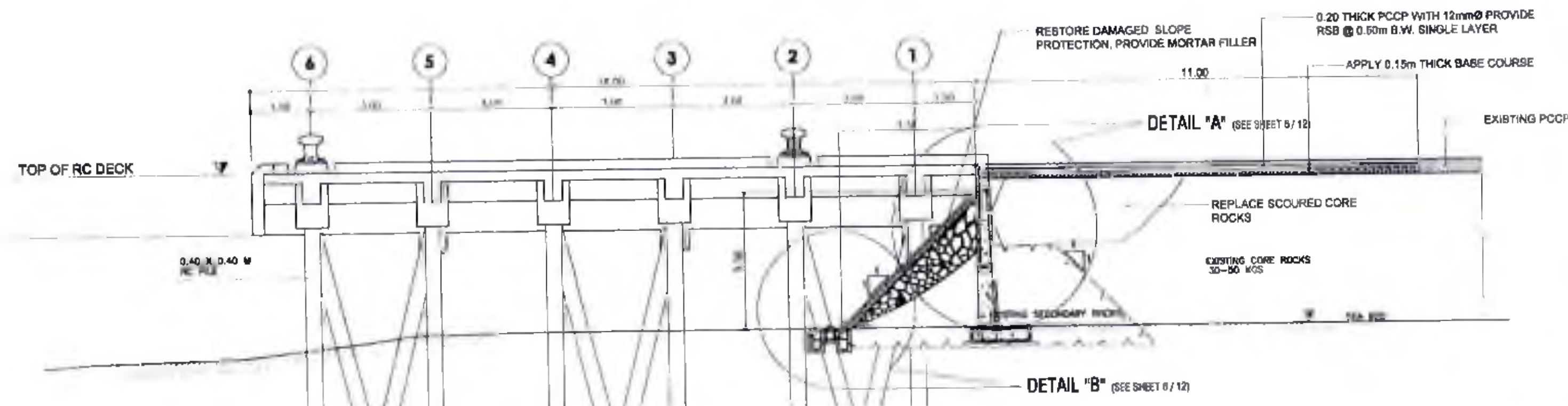

LONGITUDINAL SECTION (PROPOSED)
SCALE 1/100 METERS

 <p>PHILIPPINE PORTS AUTHORITY PORT Infrastructure Office - PALANAN 100 Alifan Drive, Palanan City, Palawan Tel: 092-234-1000, 092-234-1001 Fax: 092-234-1002, 092-234-1003</p>	<p>PROJECT TITLE AND LOCATION: REPAIR OF DAMAGED R.C. PIER, CONCRETE PAVEMENT APPROACH, SLOPE PROTECTION, BACK UP AREA AND REMOVAL OF SUNKEN DERELICTS/LOGS BGY. PUNTABAJA, RIZAL, PALAWAN</p>	<p>DESIGNED BY:  HELLY W. MADARCOS SENIOR ENGINEER A</p>	<p>CHECKED BY:  MARLON N. SEMAYDICO ENGINEER</p>	<p>APPROVED BY:  ELIZALDE M. ULSON ACTING PORT MANAGER</p>	<p>FILE NAME: RIZAL PORT REPAIR 2021</p>	<p>SHEET NO. C-1 04/12</p>
--	---	--	--	--	---	---

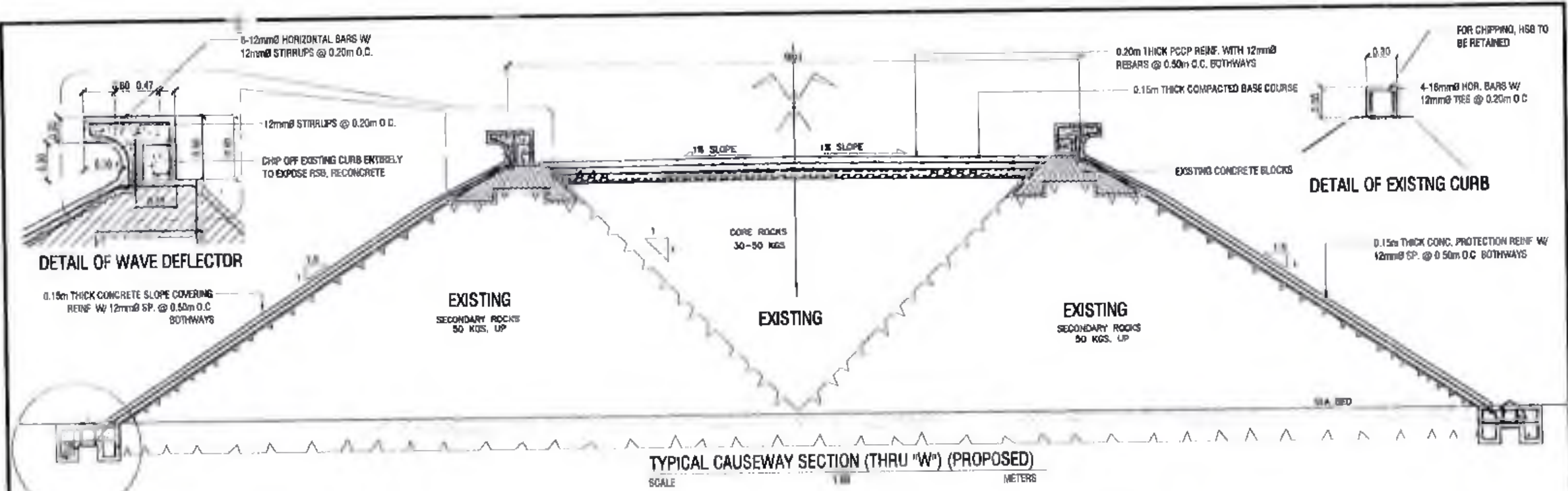

TYPICAL CAUSEWAY SECTION (THRU "W") (PROPOSED)
SCALE 1:100 METERS

SEE DETAIL "B" (SEE SHEET 6 / 12)

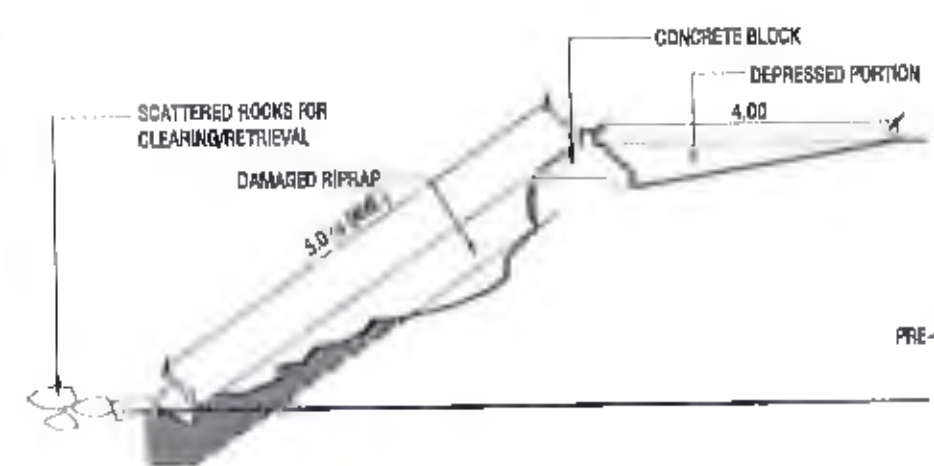

SECTION THRU "X" (EXISTING)
(REFER TO SHEET 2 / 12)
SCALE 1:100 METERS

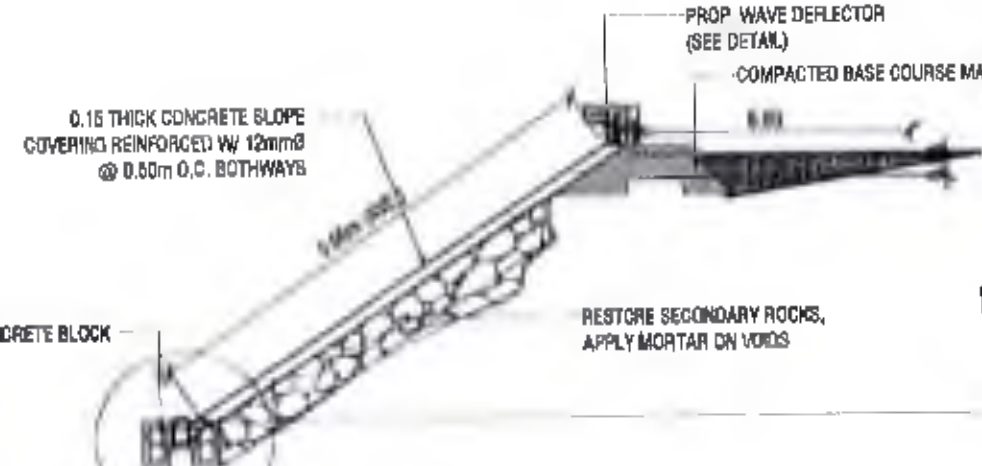

SECTION THRU "X" (PROPOSED)
(REFER TO SHEET 2 / 12)
SCALE 1:100 METERS

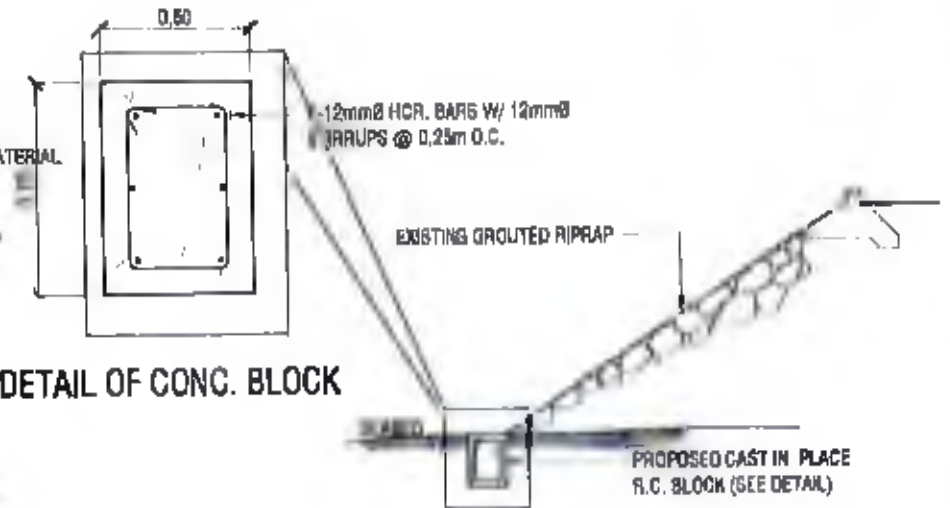

SECTION THRU "Y" (PROPOSED)
(REFER TO SHEET 2 / 12)
SCALE 1:100 METERS

	PROJECT TITLE AND LOCATION: REPAIR OF DAMAGED R.C. PIER, CONCRETE PAYMENT APPROACH, SLOPE PROTECTION, BACK UP AREA AND REMOVAL OF SUNKEN DERELICTS/LOGS BIGY, PUNTARAJA RIZAL, PALAWAN	DESIGNED BY: RELY W. MADARCOS SENIOR ENGINEER &	CHECKED BY: PARLOW B. BENDAYADIEGO SENIOR ENGINEER	APPROVED BY: ELIZALDE M. ULSON ACTING PORT MANAGER	SHEET CONTENTS: FILE NAME: RIZAL PORT REPAIR 2021	SHEET NO. C-1 05 12
	SCALE 1:100 METERS					

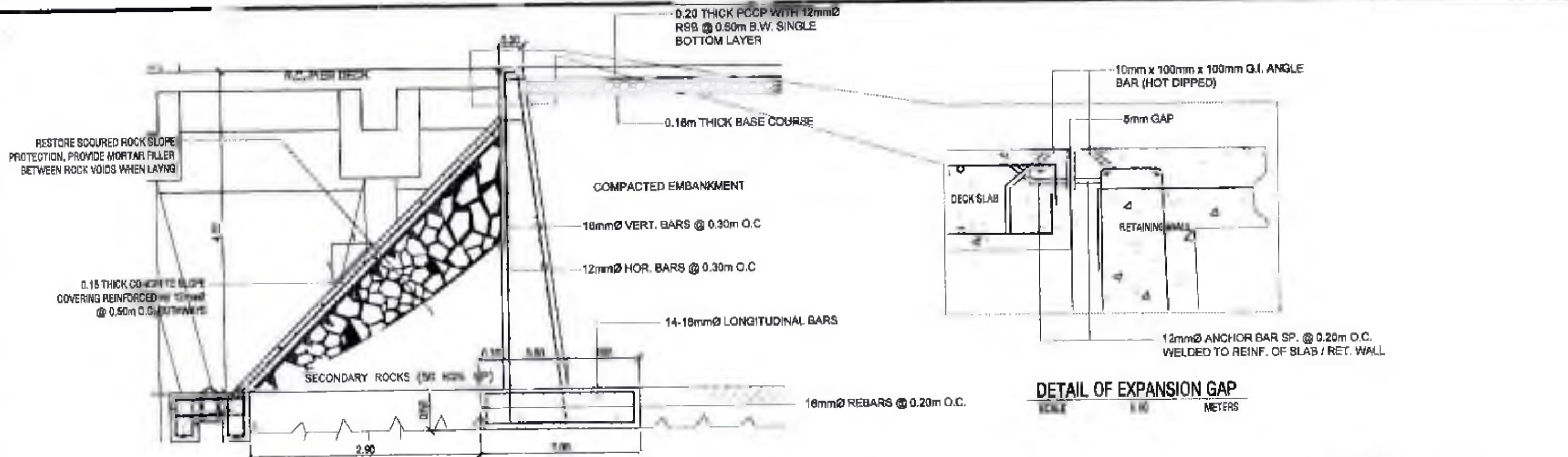

DETAIL "A": SECTION OF RETAINING WALL
SCALE 1/10 METERS

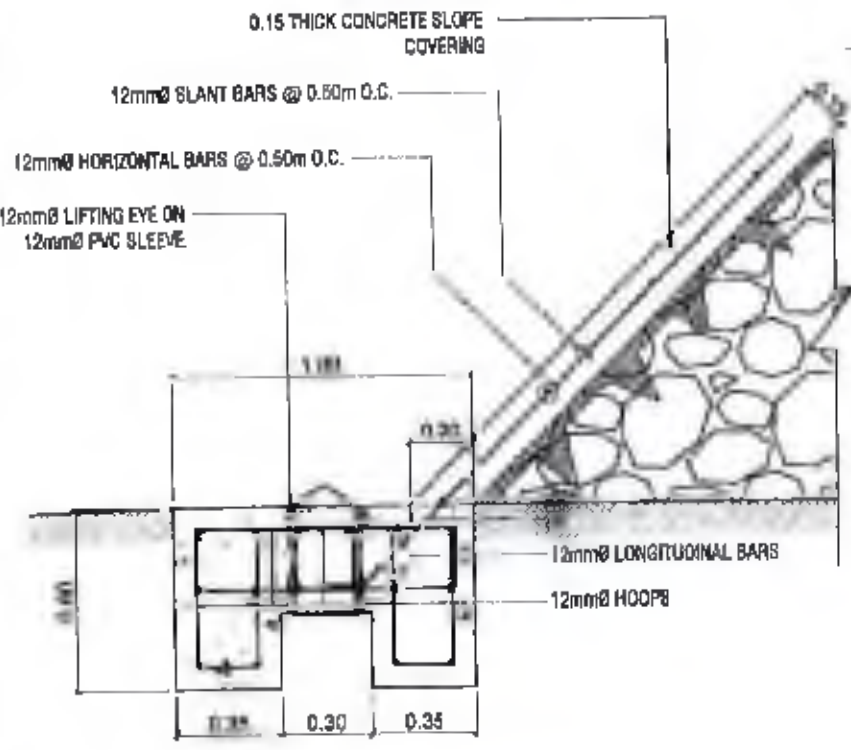

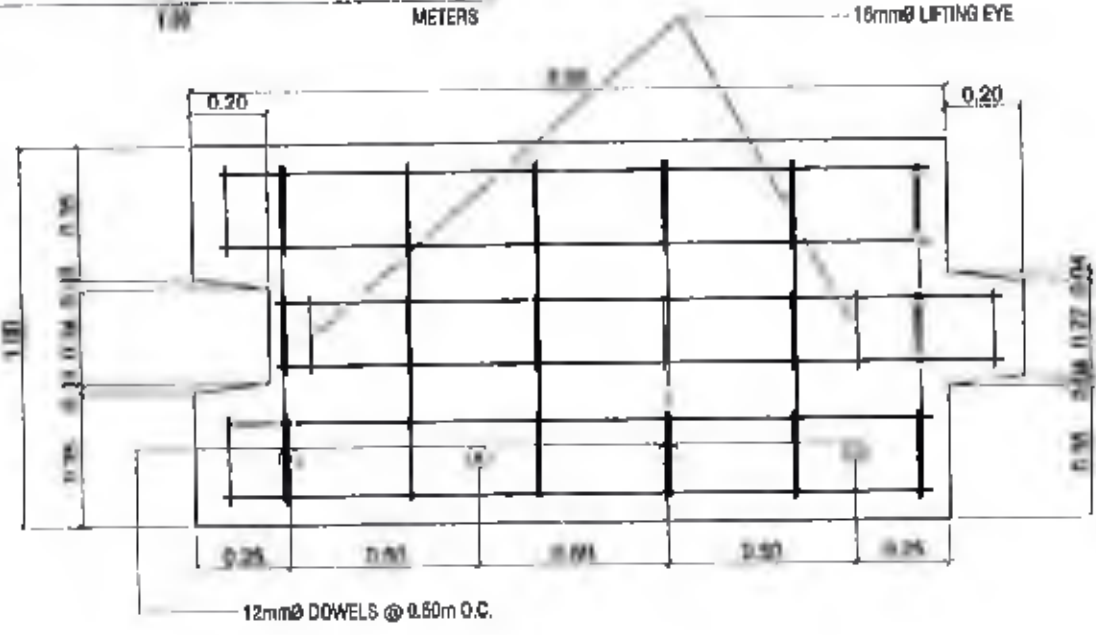

DETAIL "B": SECTION OF CONCRETE BLOCK / R.C. SLOPE PROTECTION
SCALE 1/25 METERS

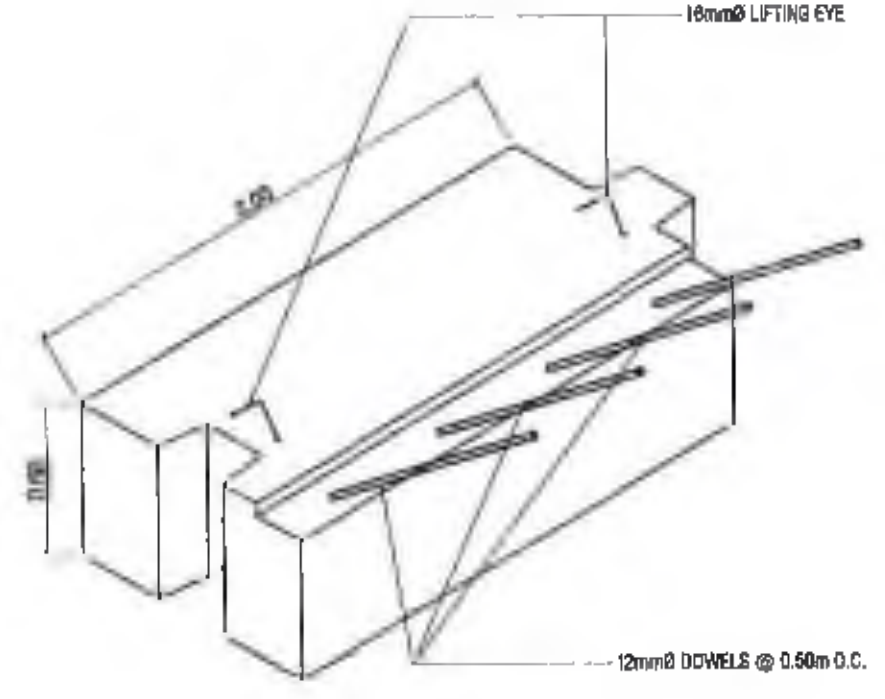

PLAN DETAIL OF CONCRETE BLOCK
SCALE 1/20 METERS

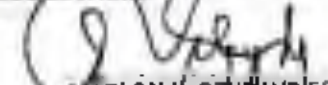
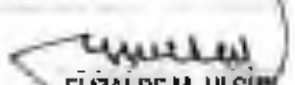

ISOMETRY OF CONCRETE BLOCK
SCALE 1/30 METERS

 <p>PHILIPPINE PORTS AUTHORITY PORT MANAGEMENT OFFICE - PALANAN PWA Administrative Building, Port Area, New Manila, Palanan, Palawan City, Palawan Under the Direct Control of the Department of Transportation</p>	<p>PROJECT TITLE AND LOCATION: REPAIR OF DAMAGED R.C. PIER, CONCRETE PAYEMENT APPROACH, SLOPE PROTECTION, BACK UP AREA AND REMOVAL OF SUNKEN DERELICTS/LOGS BGY. PUNTABAJA, RIZAL, PALAWAN</p>	<p>DRAWN BY:  RELY M. MADARCOS SENIOR ENGINEER A</p>	<p>DESIGNED BY:  MARLON M. SANDOVAL SENIOR ENGINEER B</p>	<p>APPROVED BY:  ELZALDE M. ULSIN DISTRICT PORT MANAGER</p>	<p>FILE NAME : RIZAL PORT REPAIR 2021</p>	<p>SHEET NO. C-1 06/12</p>
--	--	---	--	--	---	------------------------------------

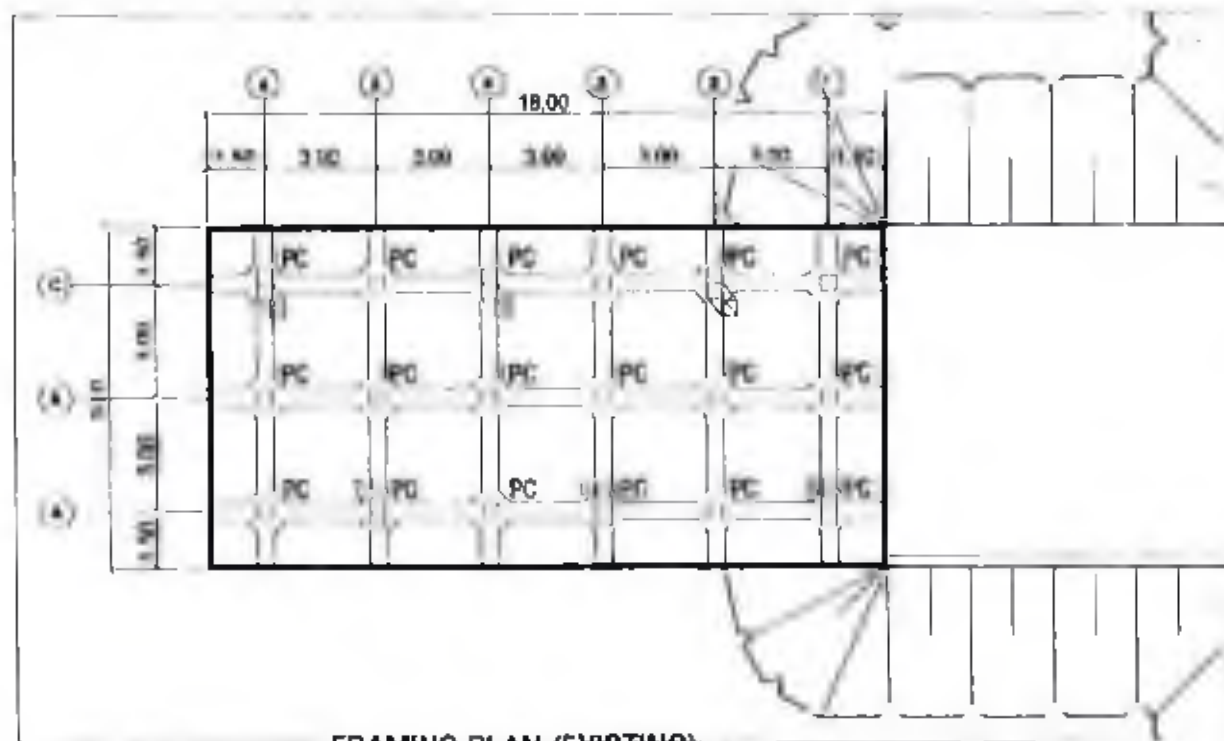

FRAMING PLAN (EXISTING)

SCALE 1:200 METERS

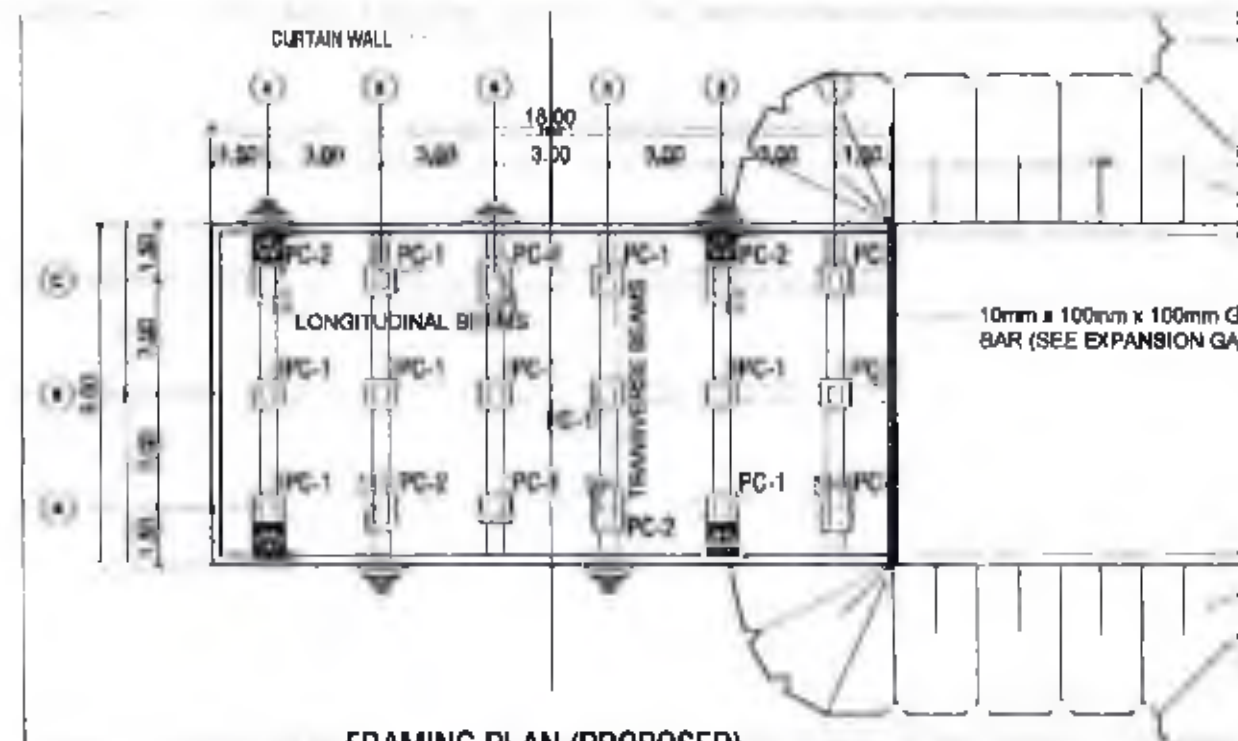

FRAMING PLAN (PROPOSED)

SCALE 1:200 METERS

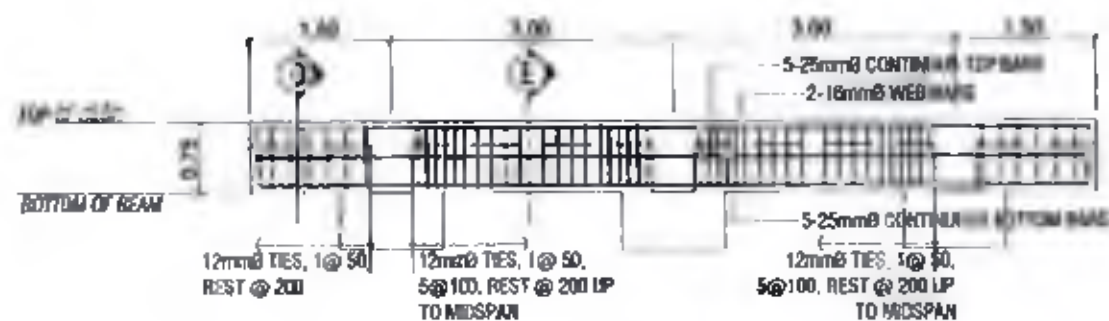

TRANSVERSE BEAM SECTION (EXISTING)

SCALE 1:200 METERS

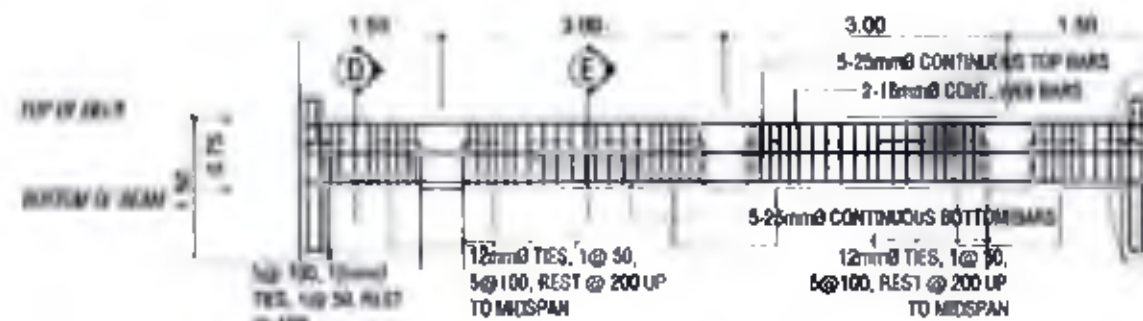

TRANSVERSE BEAM SECTION (PROPOSED)

SCALE 1:200 METERS

SEE DETAIL OF CURTAIN WALL

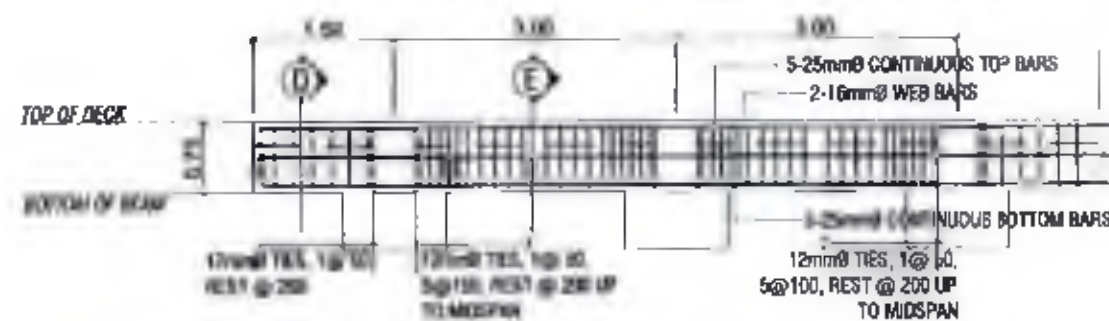

LONGITUDINAL BEAM SECTION (EXISTING)

SCALE 1:200 METERS

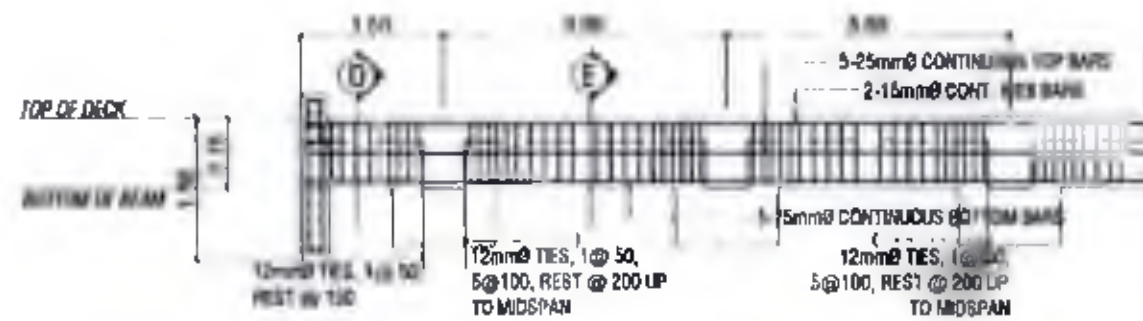

LONGITUDINAL BEAM SECTION (PROPOSED)

SCALE 1:200 METERS

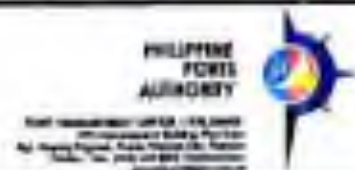

PROJECT TITLE AND LOCATION
 REPAIR OF DAMAGED R.C. PIER, CONCRETE PAVEMENT APPROACH, SLOPE PROTECTION, BACK UP AREA AND REMOVAL OF SUNKEN DERELICTS/LOGS
 BGY. PUNTAJALA, RIZAL, PALAWAN

DESIGNED BY
 REXLYN MADARCOS
 SENIOR ENGINEER A

RECOMMENDED APPROVAL
 MARLON N. SENDAYO
 SENIOR ENGINEER B

APPROVED BY
 ELIZALDE M. ULSON
 ACTING PORT MANAGER

DATE OF SHEET
 FILE NAME: RIZAL PORT REPAIR 2021

SHEET NO.
 C-1
 07/12

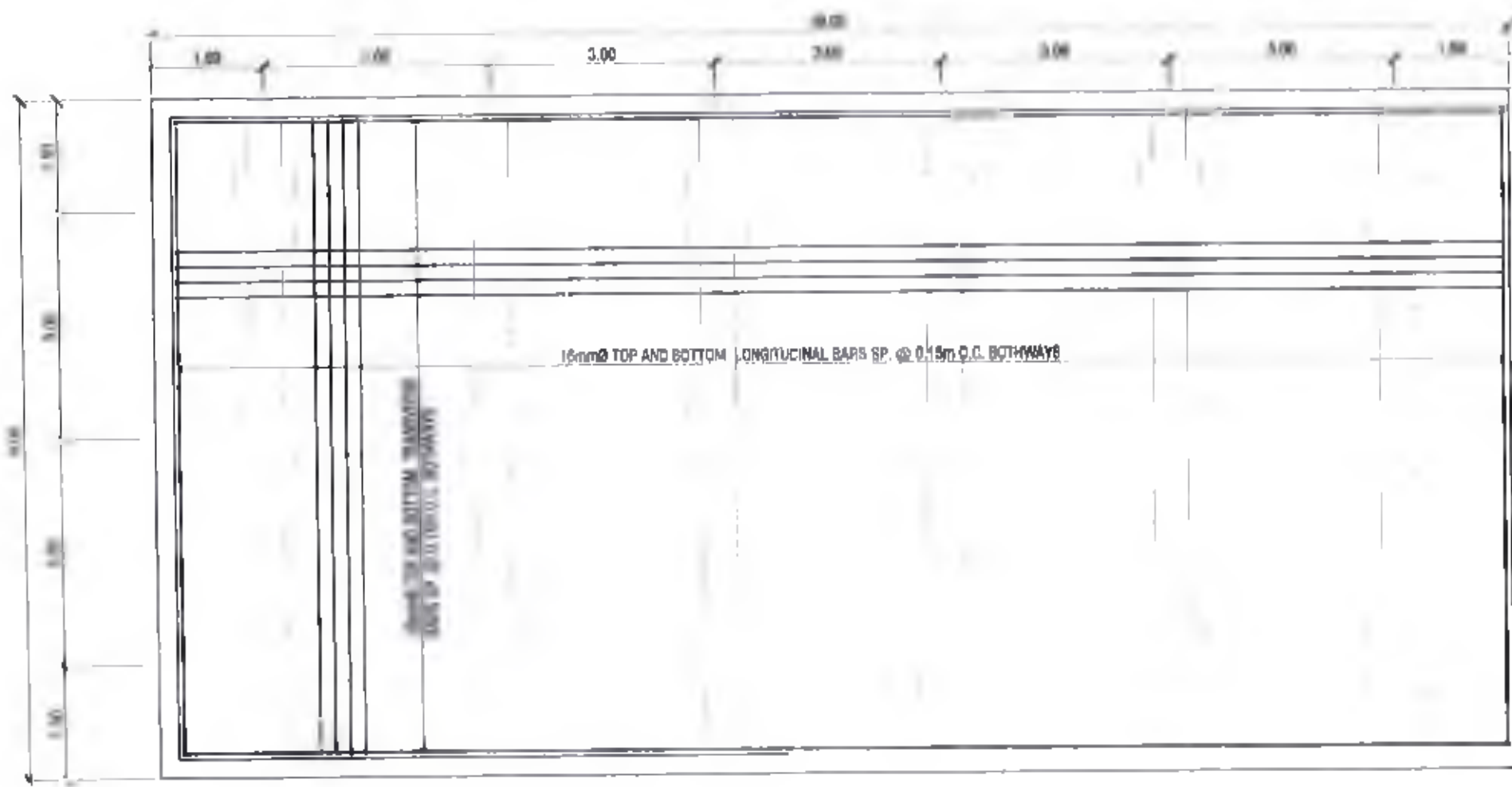

SLAB REINFORCEMENT DETAIL
SCALE 1:80 METERS

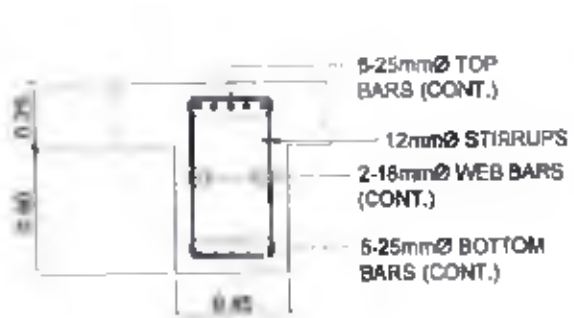

SECTION D

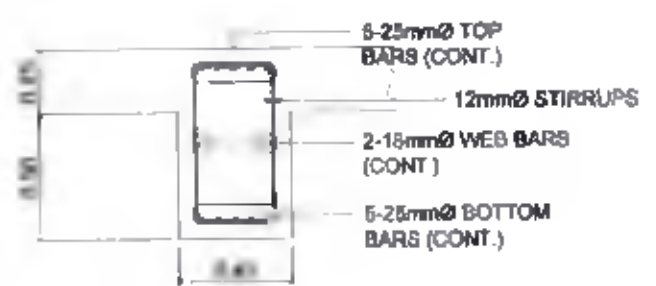

SECTION E

BEAM SECTIONS (EXISTING)
SCALE 1:30 METERS

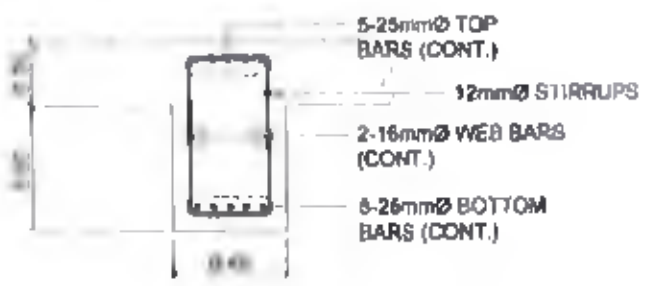

SECTION D

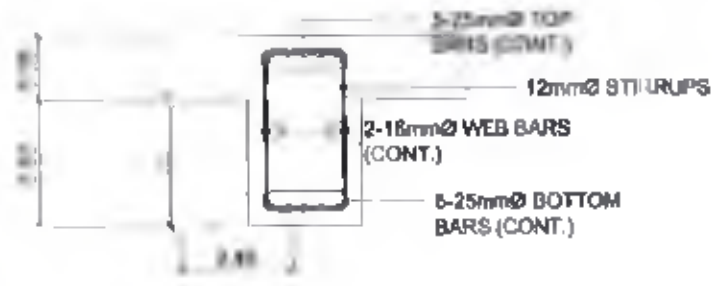

SECTION E

BEAM SECTIONS (PROPOSED)
SCALE 1:30 METERS

NOTE: MAINTAIN 75mm CONCRETE COVER FOR BEAMS AND PILE CAPS, 50mm FOR SLABS AND CURTAIN WALL

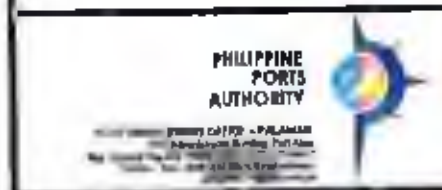

PROJECT TITLE AND LOCATION:
REPAIR OF DAMAGED R.C. PIER, CONCRETE PAVEMENT APPROACH, SLOPE PROTECTION, BACK LIP AREA AND REMOVAL OF SUNKEN DERELICTS/LOGS
BGY. PUNTABAJA, RIZAL, PALAWAN

RECOMMENDED APPROVAL:
[Signature]
RELLY W. MADARCOS
SENIOR ENGINEER A

RECOMMENDED APPROVAL:
[Signature]
JANLON N. SENDAYDIGO

RECOMMENDED APPROVAL:
[Signature]
ELIZALDE M. OLSON
ACTING PORT MANAGER

FILE NAME: RIZAL PORT REPAIR 2021

SHEET NO.
C-1
08 12

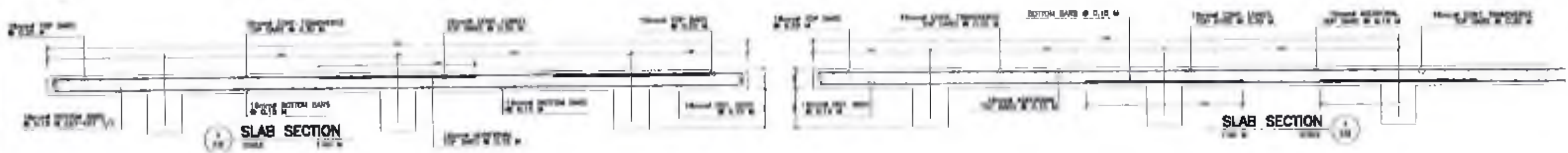

CROSS SECTION

SLAB REINFORCEMENT DETAIL (EXISTING)

LONGITUDINAL SECTION

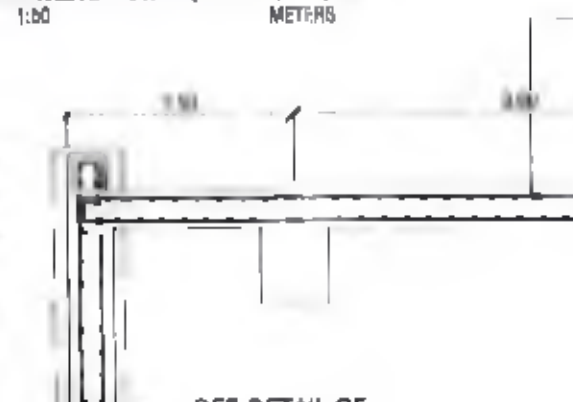
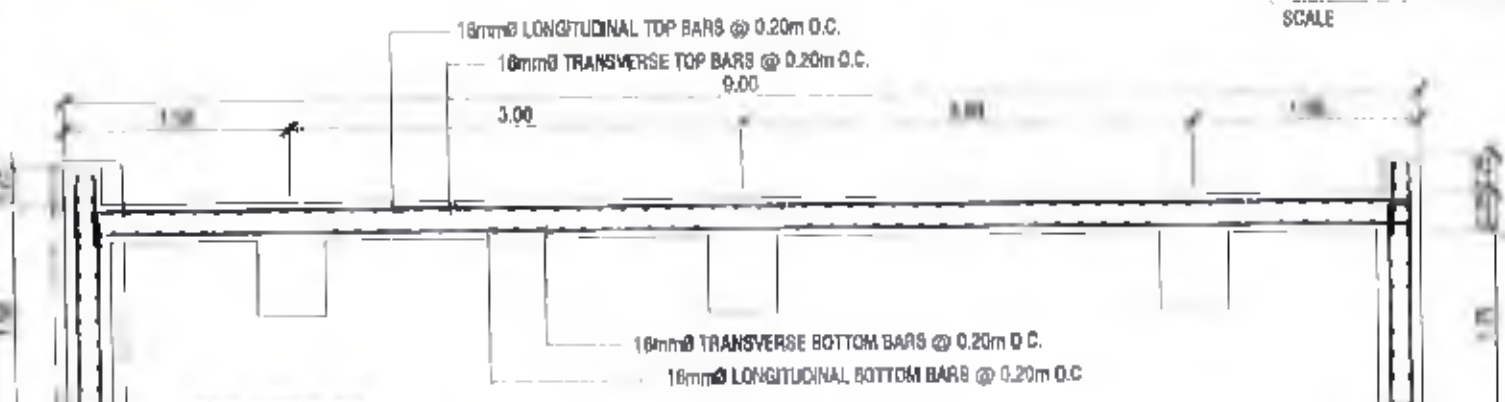

CROSS SECTION

SLAB REINFORCEMENT DETAIL (PROPOSED)

LONGITUDINAL SECTION

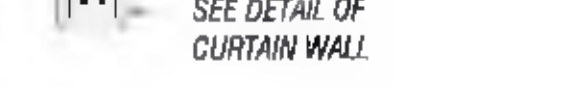
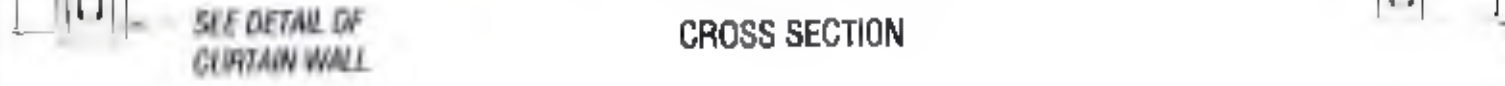

NOTE: MAINTAIN 75mm CONCRETE COVER FOR BEAMS AND PILE CAPS, 50mm FOR SLABS AND CURTAIN WALL

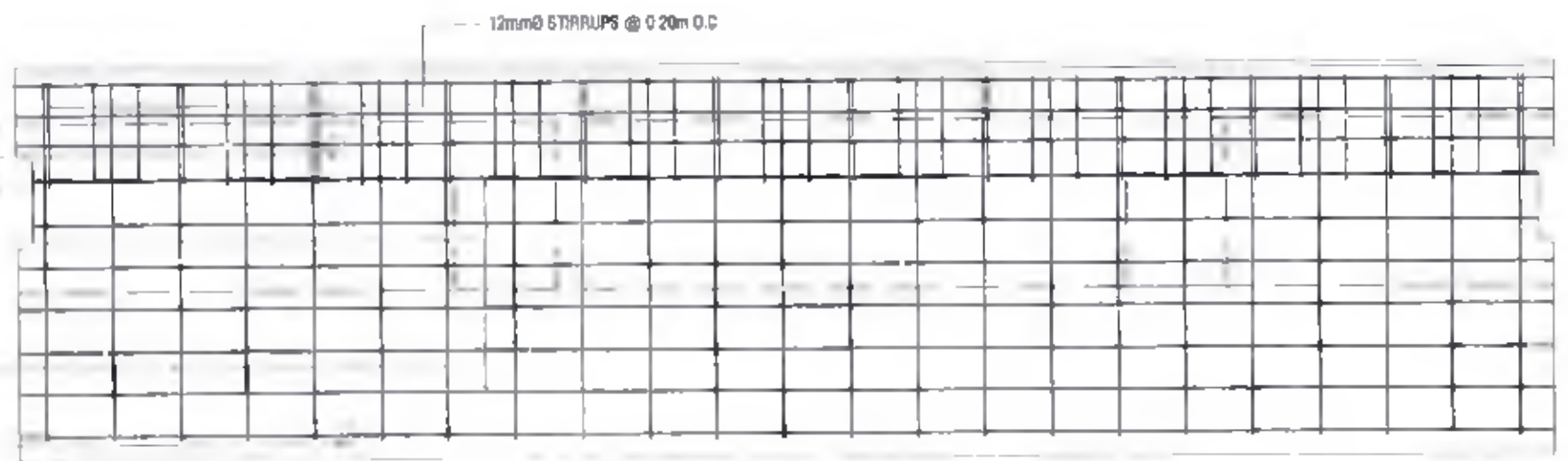
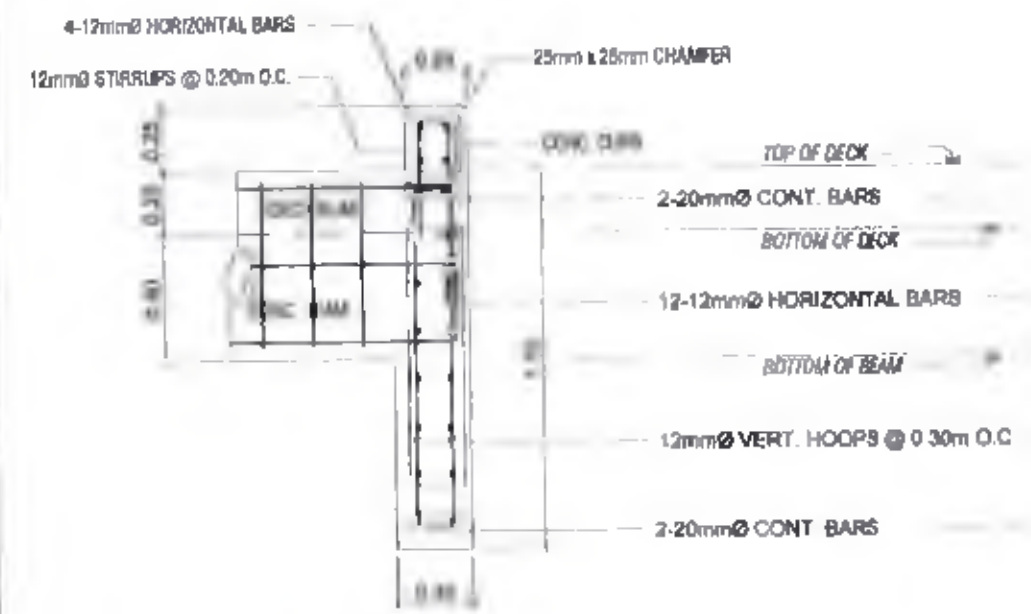

CROSS SECTION DETAIL OF CURTAIN WALL

LONGITUDINAL SECTION DETAIL OF CURTAIN WALL

SCALE 1:30 METERS

SCALE 1:30 METERS

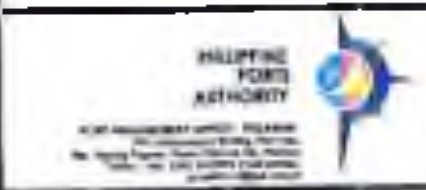

PROJECT TITLE AND LOCATION:
REPAIR OF DAMAGED R.C. PIER, CONCRETE PAVEMENT APPROACH, SLOPE PROTECTION, BACK UP AREA AND REMOVAL OF SUNKEN DERELICTS/LOGS
ROY PUJARASA RIZAL, PALAWAN

WILLY W. M. DARCOS
SENIOR ENGINEER A

MARLON N. SERRANO
ENGINEER

ELIZALDE M. ULSON
ACTING PORT MANAGER

C-1
09/12
FILE NAME: RIZAL PORT REPAIR 2011

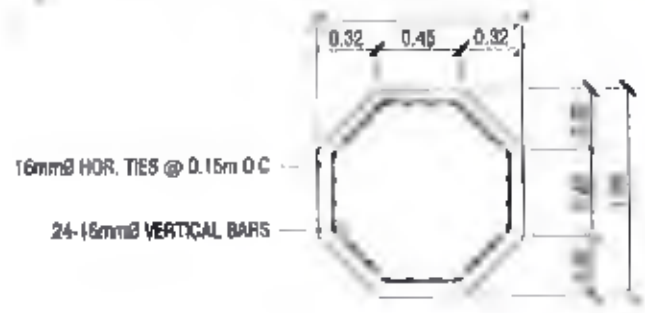

PLAN SECTION

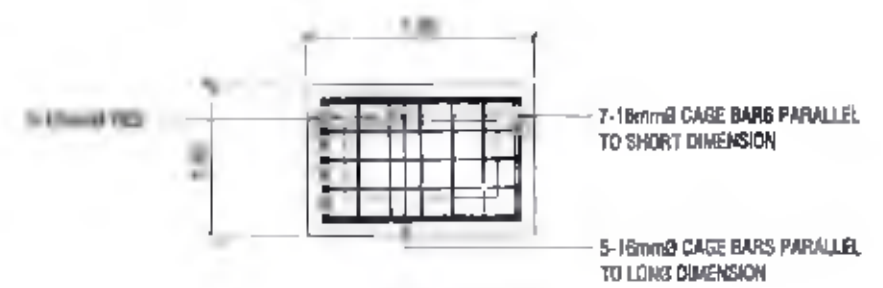

PLAN SECTION



PLAN SECTION

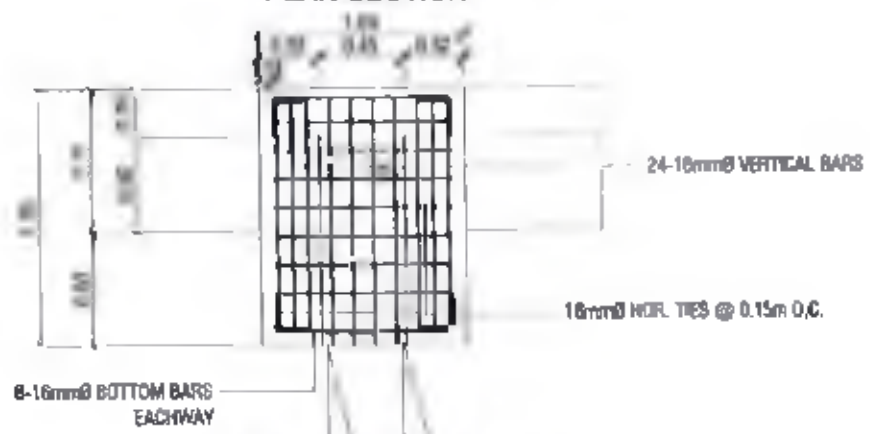

ELEVATION SECTION

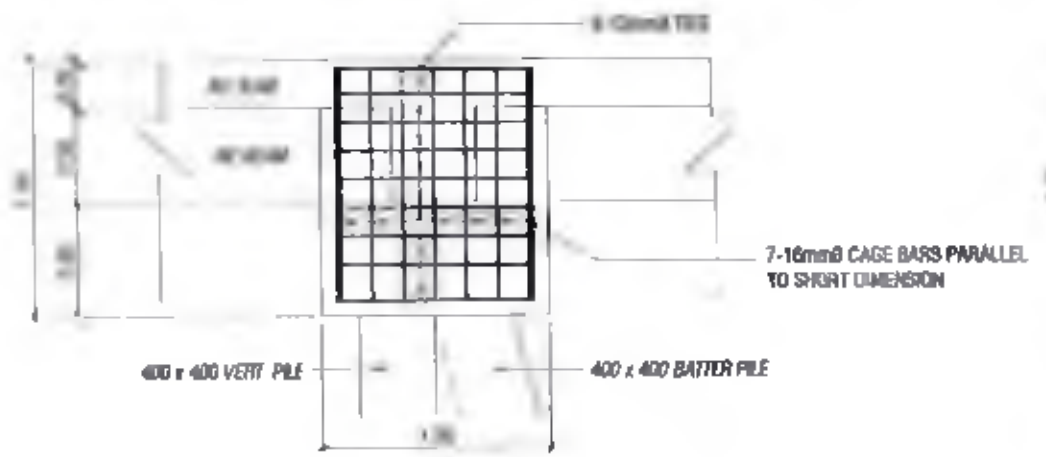

ELEVATION SECTION

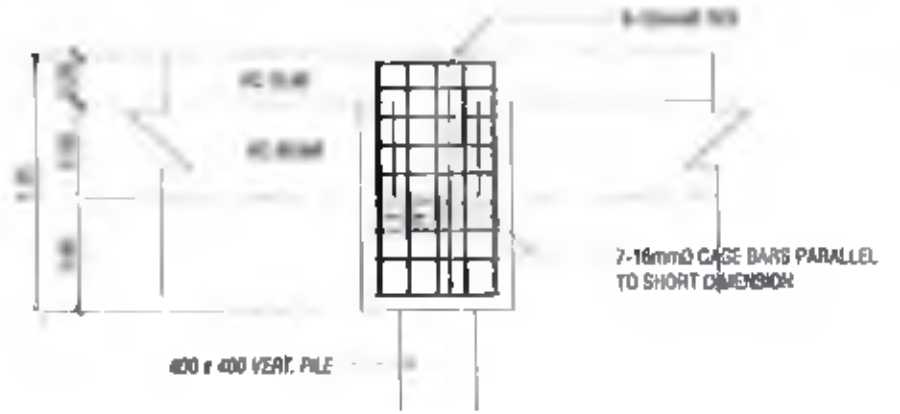

ELEVATION SECTION

PILE CAP DETAIL (EXISTING)
SCALE 1:40 METERS

DOUBLE PILE PILE CAP DETAIL, PC-2 (PROPOSED)
SCALE 1:40 METERS

SINGLE PILE PILE CAP DETAIL, PC-1 (PROPOSED)
SCALE 1:40 METERS

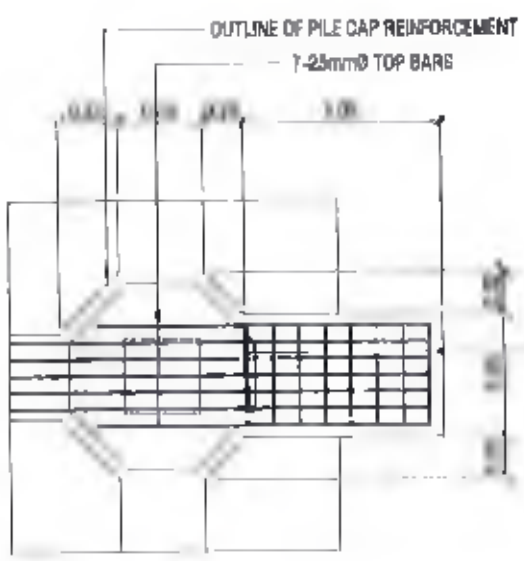

PLAN SECTION

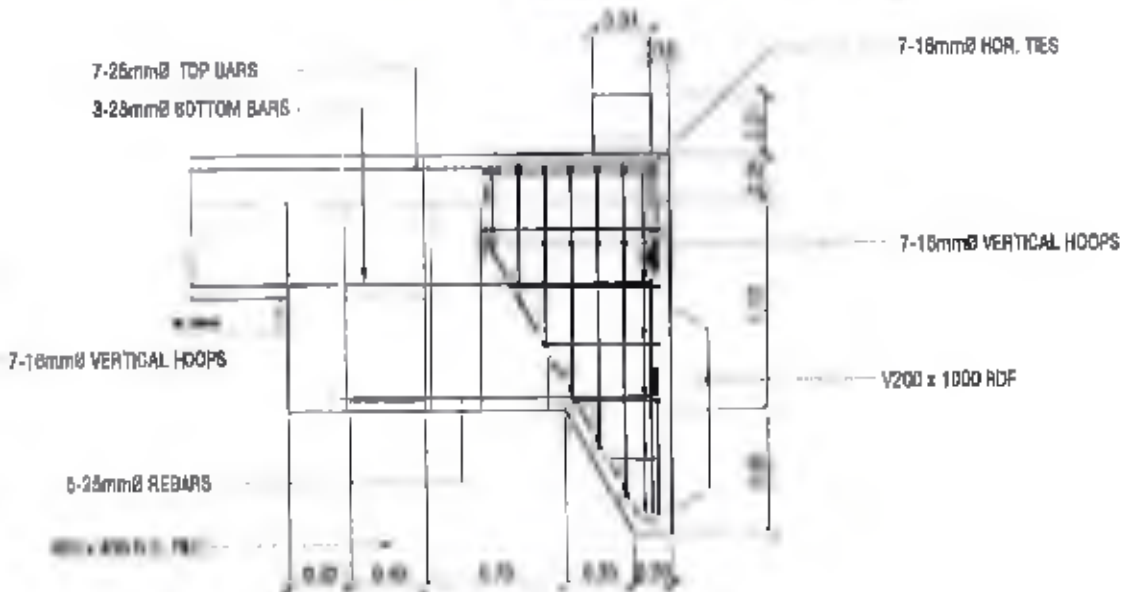

ELEVATION SECTION

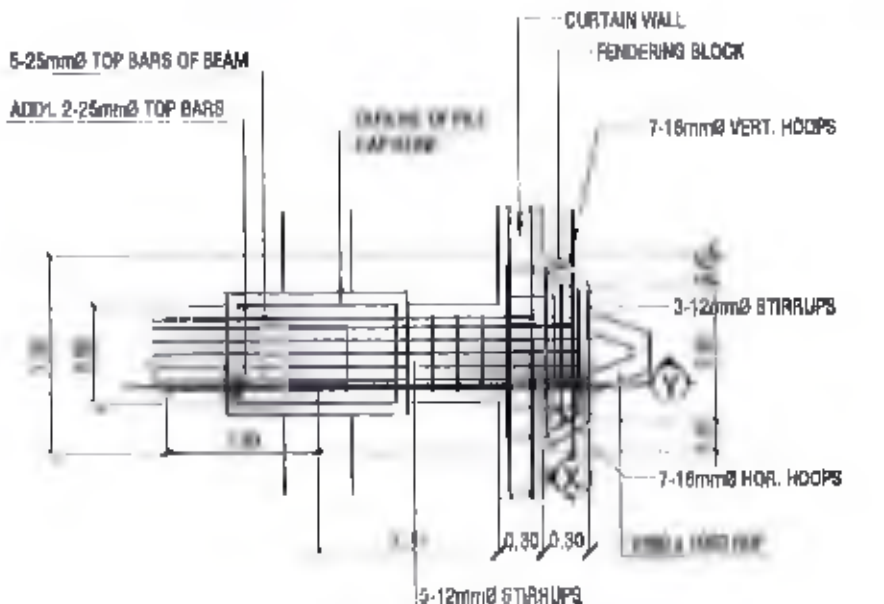

PROPOSED FENDER BLOCK PLAN
SHOWING REINFORCEMENT (@ DOUBLE PILE CAP)

FENDER BLOCK DETAIL (EXISTING)
SCALE 1:40 METERS

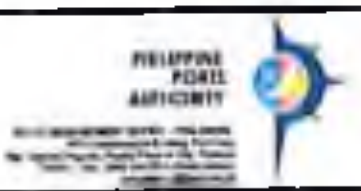

PROJECT TITLE AND LOCATION:
REPAIR OF DAMAGED R.C. PIER, CONCRETE
PAYMENT APPROACH, SLOPE PROTECTION, BACK UP
AREA AND REMOVAL OF SUNKEN DERELICTS/LOGS
BCY, PUNTABALA, RIZAL, PALAWAN

NEILY W. MADARCOS
SENIOR ENGINEER A

MARILYN N. SENDAYONG

ELIZALDE M. ULSSON
ACTING PORT MANAGER

FILE NAME : RIZAL FOR1 REPAIR 2021

C-1
10 12



Section VIII.
Bill of Quantities

SUMMARY OF BILL OF QUANTITIES

NRP-PLW-02-21 REPAIR OF DAMAGED R.C. PIER, CONCRETE PAVEMENT APPROACH, SLOPE PROTECTION, BACK-UP REA AND REMOVAL OF SUNKEN
DERELICTS/LOGS
PORT OF RIZAL, BRGY. PUNTABAJA, RIZAL, PALAWAN

NO. (1)	DESCRIPTION OF WORK (2)	UNIT (3)	QTY. (4)	UNIT PRICE (Pesos) (5)	AMOUNT (Pesos) (4)x(5)
BILL NO. I	GENERAL EXPENSES	LOT	1.00	P	P
BILL NO. II	REPAIR OF CAUSEWAY APPROACH	CUM	111.87		
BILL NO. III	REPAIR OF BACK-UP AREA	CUM	24.00		
BILL NO. IV	REPAIR OF SLOPE PROTECTION	CUM	384.16		
BILL NO. V	REPAIR OF R.C. PIER	SQM	162.00		
BILL NO. VI	REPAIR OF RETAINING WALL	CUM	28.77		
BILL NO. VII	REMOVAL OF SUNKEN DERELICT AROUND THE PERIPHERY OF R.C. PIER	LOT	1.00		
BILL NO. VIII	CLEARING WORKS	LOT	1.00		
TOTAL BILL FOR THE CONTRACT					P

Bidder's Authorized Representative

NRP-PLW-02-21 REPAIR OF DAMAGED R.C. PIER, CONCRETE PAVEMENT APPROACH, SLOPE PROTECTION, BACK-UP REA AND REMOVAL OF SUNKEN DERELICTS/LOGS
PORT OF RIZAL, BRGY. PUNTABAJA, RIZAL, PALAWAN

NO. (1)	DESCRIPTION OF WORK (2)	UNIT (3)	QTY. (4)	UNIT PRICE (Pesos) (5)	AMOUNT (Pesos) (4)x(5)
BILL NO. 1	GENERAL EXPENSES				
1.01	Mobilization and Demobilization	lot	1	₱	₱
1.02	Provide Safety and Health Program in the Execution of the Project	lot	1		
1.03	Provision of Temporary Facility (Field Office and Engineer's Quarter)	lot	1		
TOTAL FOR BILL NO. 1					₱

Bidder's Authorized Representative

BILL OF QUANTITIES

NRP-PLW-02-21 REPAIR OF DAMAGED R.C. PIER, CONCRETE PAVEMENT APPROACH, SLOPE PROTECTION, BACK-UP REA AND REMOVAL OF SUNKEN DERELICTS/LOGS
PORT OF RIZAL, BRGY. PUNTABAJA, RIZAL, PALAWAN

NO. (1)	DESCRIPTION OF WORK (2)	UNIT (3)	QTY. (4)	UNIT PRICE (Pesos) (5)	AMOUNT (Pesos) (4)x(5)
BILL NO. II	REPAIR OF ROCK CAUSEWAY APPROACH				
2.01	Supply and Placement of Core Rock for Scoured Portion of Rock Causeway	cum	88.45	₱	₱
2.02	Demolition and Disposal of existing PCCP on top of causway	cum	10.38		
2.03	Supply, Place and Compact Base Course Material on top of Causeway	cum	13.04		
2.04	Fabricate and Install RSB for Item No.2.05	kgs	341		
2.05	Supply and Placement of 3500 psl Concrete for PCCP on top of Causeway	cum	17.38		
TOTAL FOR BILL NO. II					₱

Bidder's Authorized Representative

BILL OF QUANTITIES

NRP-PLW-02-21 REPAIR OF DAMAGED R.C. PIER, CONCRETE PAVEMENT APPROACH, SLOPE PROTECTION, BACK-UP REA AND REMOVAL OF SUNKEN DERELICTS/LOGS
PORT OF RIZAL, BRGY. PUNTABAJA, RIZAL, PALAWAN

NO. (1)	DESCRIPTION OF WORK (2)	UNIT (3)	QTY. (4)	UNIT PRICE (Pesos) (5)	AMOUNT (Pesos) (4)x(5)
BILL NO. III	REPAIR OF BACK-UP AREA				
3.01	Supply, Place and Compact Base Course Material at Depressed Portion of Back-up Area	cum	24.00	P	P
TOTAL FOR BILL NO. III					P

Bidder's Authorized Representative

BILL OF QUANTITIES

NRP-PLW-02-21 REPAIR OF DAMAGED R.C. PIER, CONCRETE PAVEMENT APPROACH, SLOPE PROTECTION, BACK-UP REA AND REMOVAL OF SUNKEN DERELICTS/LOGS
PORT OF RIZAL, BRGY. PUNTABAJA, RIZAL, PALAWAN

NO. (1)	DESCRIPTION OF WORK (2)	UNIT (3)	QTY. (4)	UNIT PRICE (Pesos) (5)	AMOUNT (Pesos) (4)x(5)
BILL NO. IV	REPAIR OF SLOPE PROTECTION				
4.01	Retrieval of Scattered Secondary Rocks	cum	138.36	P	P
4.02	Placement of Secondary Rocks (retrieved and supplied) for Scoured Slope Protection	cum	214.54		
4.03	Placement of Concrete Grout on Item 4.02	cum	64.36		
4.04	Excavation of seabed for Concrete Block Footing (pre-cast & cast in place blocks)	cum	84.04		
4.05	Fabricate and Install RSB for Item No. 4.06	kgs	3,262.55		
4.06	Supply & Placement of 3500 psi Concrete Block (Pre-cast) Footing	cum	55.13		
4.07	Install Concrete Block (Pre-cast) Footing	cum	55.13		
4.08	Fabricate & Install RSB for Item No. 4.09	kgs	2,029.97		
4.09	Supply and Placement 3500 psi Concrete for Slope Covering	cum	63.49		
4.10	Fabricate and Install RSB for Item No. 4.11	kgs	809.86		
4.11	Supply & Placement of 3500 psi Concrete for Concrete Block (Cast in place) Footing	cum	21.00		
4.12	Chipping of Existing Curb	cum	9.63		
4.13	Fabricate and Install RSB for Item No. 4.14	kgs	1657.01		
4.14	Supply and Placement of 3500 psi Concrete for Wave Deflector	cum	30.00		
TOTAL FOR BILL NO. IV					P

Bidder's Authorized Representative

BILL OF QUANTITIES

NRP-PLW-02-21 REPAIR OF DAMAGED R.C. PIER, CONCRETE PAVEMENT APPROACH, SLOPE PROTECTION, BACK-UP REA AND REMOVAL OF SUNKEN DERELICTS/LOGS
PORT OF RIZAL, BRGY. PUNTABAJA, RIZAL, PALAWAN

NO. (1)	DESCRIPTION OF WORK (2)	UNIT (3)	QTY. (4)	UNIT PRICE (Pesos) (5)	AMOUNT (Pesos) (4)x(5)
BILL NO. V	REPAIR OF R.C. PIER				
5.01	Removal of Rubber Dock Fenders and Mooring Bollards	unit	9.00	P	P
5.02	Demolition & Disposal of Concrete Debris (Curbs, Bollard Base, Fender Block, RC Deck, RC Beams and Pile Caps)	cum	94.35		
5.03	Supply & Install Steel Reinforcement for Pile caps, Beams, deck Bollard Base, Fender Blocks, Curtain Wall and Curbs	kgs	18439.10		
5.04	Supply & Placement of 3500 psi Concrete for Pile Caps, Beams, Deck, Bollard Base, Fender Blocks, Curtain Wall & Curbs	cum	103.69		
5.05	Supply & Delivery Rubber Dock Fenders, V400 x 1000, including Accessories	sets	5.00		
5.06	Install Rubber Dock Fenders, V400 x 1000	sets	5.00		
5.07	Supply & Delivery 25T T-Head Cast Iron Mooring Bollard, including Accessories	sets	4.00		
5.08	Install 25T T-Head Cast Iron Mooring Bollard	sets	4.00		
5.09	Supply & Install Edge Protection, 100mm x 100mm x 10mm x 6m Angle Bar, Hot Dipped Galvanized	l.m.	18.00		
TOTAL FOR BILL NO. V					

Bidder's Authorized Representative

NRP-PLW-02-21 REPAIR OF DAMAGED R.C. PIER, CONCRETE PAVEMENT APPROACH, SLOPE PROTECTION, BACK-UP REA AND REMOVAL OF SUNKEN DERELICTS/LOGS
 PORT OF RIZAL, BRGY. PUNTABAJA, RIZAL, PALAWAN

NO. (1)	DESCRIPTION OF WORK (2)	UNIT (3)	QTY. (4)	UNIT PRICE (Pesos) (5)	AMOUNT (Pesos) (4)x(5)
BILL NO. VI	RETAINING OF RETAINING WALL				
6.01	Demolition of Damaged Retaining Wall	cum	9.00	P	P
6.02	Extraction of Secondary Rocks Affected by Foundation of Retaining Wall	cum	83.05		
6.03	Supply & Install Steel Reinforcement for Footing & Stem of RC Wall	kgs	1812.41		
6.04	Supply & Placement of 3500 psi Concrete for Footing & Stem of RC Wall	cum	28.77		
TOTAL FOR BILL NO. VI				P	

Bidder's Authorized Representative

BILL OF QUANTITIES

NRP-PLW-02-21 REPAIR OF DAMAGED R.C. PIER, CONCRETE PAVEMENT APPROACH, SLOPE PROTECTION, BACK-UP REA AND REMOVAL OF SUNKEN DERELICTS/LOGS
PORT OF RIZAL, BRGY. PUNTABAJA, RIZAL, PALAWAN

NO. (1)	DESCRIPTION OF WORK (2)	UNIT (3)	QTY. (4)	UNIT PRICE (Pesos) (5)	AMOUNT (Pesos) (4)x(5)
BILL NO. VIII	CLEAN, CLEAR & DISPOSE CONSTRUCTION WASTES & DEBRIS				
8.01	Clear, Clean and Dispose Construction Wastes and Debris	lot	1.00	P	P
8.02	Transport of Salvage Materials (Bollards, RDFs, Steel Bars) from Site to Baseport	lot	1.00		
TOTAL FOR BILL NO. VIII					P

Bidder's Authorized Representative

BASIS OF PAYMENT FOR WORK ITEMS INCLUDED IN THE PROPOSAL

The work items included in the proposal including the basis of payment for each item are as follows:

BILL NO. 1 – GENERAL EXPENSES

Item 1.01 Mobilization and Demobilization

The quantity to be paid for shall be the actual number of minimum equipment requirement enumerated in the bid documents mobilized and demobilized. The contract lump sum price shall be full compensation for furnishing all materials, labor, equipment, tools and incidentals necessary to mobilize and demobilize all the minimum equipment requirement enumerated in the bid documents. Fifty percent (50%) of the total amount shall be payable after the mobilization activity while the remaining (50%) payable after demobilization.

Item 1.02 Provide Safety and Health Programs in the Execution of the Project

The quantity to be paid for shall be the actual implementation of safety and health program and accepted by the Engineer. The contract unit price shall be full compensation for furnishing all materials, labor, equipment, tools and incidentals necessary to complete the implementation of the Construction Safety and Health Program, as required and approved by the Department of Labor and Employment (DOLE).

BILL NO. II – REPAIR OF ROCK CAUSEWAY APPROACH

Item 2.01 Supply and Placement of Core Rock for Scoured Portion of Rock Causeway (88.45 Cu.m.)

The quantity to be paid for shall be the actual volume in cubic meters of core rock to be supplied and placed for scoured portion of rock causeway in accordance with the plans and specifications and accepted by the Engineer. The contract unit price shall be full compensation for furnishing all materials, labor, equipment, tools and incidentals expenses necessary to complete the work.

Item 2.02 Demolition and Disposal of existing PCCP on top of Causeway (10.38 Cu.m.)

The quantity to be paid for shall be the actual volume in cubic meters of existing PCCP to be demolished and disposed on top of causeway in accordance with the plans and specifications and accepted by the Engineer. The contract unit price shall be full compensation for furnishing all materials, labor, equipment, tools and incidentals expenses necessary to complete the work.

Item 2.03 Supply, Place and Compact Base Course Material on top of Causeway (13.04 Cu.m.)

The quantity to be paid for shall be the actual volume in cubic meters of base course material to be supplied, placed and compacted on top of causeway in accordance with

the plans and specifications and accepted by the Engineer. The contract unit price shall be full compensation for furnishing all materials, labor, equipment, tools and incidentals expenses necessary to complete the work.

Item 2.04 Fabricate and Install RSB for Item No. 2.05 (341.00 kgs.)

The quantity to be paid for shall be the actual weight in kilograms of RSB to be fabricated and installed for Item No. 2.05 in accordance with the plans and specifications and accepted by the Engineer. The contract unit price shall be full compensation for furnishing all materials, labor, equipment, tools and incidentals expenses necessary to complete the work.

Item 2.05 Supply and Placement of 3,500 PSI Concrete for PCCP on top of Causeway (17.38 Cu.m.)

The quantity to be paid for shall be the actual volume in cubic meters 3,500 PSI concrete for PCCP to be supplied and placed on top of causeway in accordance with the plans and specifications and accepted by the Engineer. The contract unit price shall be full compensation for furnishing all materials, labor, equipment, tools and incidentals expenses necessary to complete the work.

BILL NO. III – REPAIR OF BACK-UP AREA

Item 3.01 Supply, Place and Compact Base Course Material @ Depressed Portion of Back-up Area (24.00 Cu.m.)

The quantity to be paid for shall be the actual volume in cubic meters of base course material to be supplied, placed and compacted at depressed portion of back-up area in accordance with the plans and specifications and accepted by the Engineer. The contract unit price shall be full compensation for furnishing all materials, labor, equipment, tools and incidentals expenses necessary to complete the work.

BILL NO. IV – REPAIR OF SLOPE PROTECTION

Item 4.01 Retrieval of Scattered Secondary Rocks (138.26 Cu.m.)

The quantity to be paid for shall be the actual volume in cubic meters of scattered secondary rocks to be retrieved in accordance with the plans and specifications and accepted by the Engineer. The contract unit price shall be full compensation for furnishing all materials, labor, equipment, tools and incidentals expenses necessary to complete the work.

Item 4.02 Placement of Secondary Rocks (retrieved and supplied) for Scoured Slope Protection (214.54 Cu.m.)

The quantity to be paid for shall be the actual volume in cubic meters of secondary rocks (retrieved and supplied) to be placed for scoured slope protection in accordance with the plans and specifications and accepted by the Engineer. The contract unit price shall be full compensation for furnishing all materials, labor, equipment, tools and incidentals expenses necessary to complete the work.

Item 4.03 Placement of Concrete Grout on Item 4.02 (64.36 cu.m.)

The quantity to be paid for shall be the actual volume in cubic meters of concrete grout to be placed on item 4.02 in accordance with the plans and specifications and accepted by the Engineer. The contract unit price shall be full compensation for furnishing all materials, labor, equipment, tools and incidentals expenses necessary to complete the work.

Item 4.04 Excavation of seabed for Concrete Block Footing (pre-cast and cast in place blocks) (84.04 Cu.m.)

The quantity to be paid for shall be the actual volume in cubic meters of seabed to be excavated for concrete block footing (pre-cast and cast in place blocks) in accordance with the plans and specifications and accepted by the Engineer. The contract unit price shall be full compensation for furnishing all materials, labor, equipment, tools and incidentals expenses necessary to complete the work.

Item 4.05 Fabricate and Install RSB for Item No. 4.06 (3,262.55kgs.)

The quantity to be paid for shall be actual weight in kilograms of RSB to be fabricated and installed for Item 4.06 in accordance with the plans and specifications and accepted by the Engineer. The contract unit price shall be full compensation for furnishing all materials, labor, equipment tools and incidentals expenses necessary to complete the work.

Item 4.06 Supply and Placement 3500 psi Concrete for Slope Covering (55.13 Cu.m.)

The quantity to be paid for shall be the actual volume in cubic meters of 3,500 PSI concrete to be supplied and placed for slope covering in accordance with the plans and specifications and accepted by the Engineer. The contract unit price shall be full compensation for furnishing all materials, labor, equipment, tools and incidentals expenses necessary to complete the work.

Item 4.07 Install Concrete Block (Pre-cast) Footing (55.13 Cu.m.)

The quantity to be paid for shall be the actual volume in cubic meters of concrete block (pre-cast) footing to be installed in accordance with the plans volume in cubic meters and specifications and accepted by the Engineer. The contract unit price shall be full compensation for furnishing all materials, labor, equipment, tools and incidentals expenses necessary to complete the work.

Item 4.08 Fabricate and Install RSB for Item No. 4.09 (2,029.97kgs.)

The quantity to be paid for shall be actual weight in kilograms of RSB to be fabricated and installed for Item 4.09 in accordance with the plans and specifications and accepted by the Engineer. The contract unit price shall be full compensation for furnishing all materials, labor, equipment, tools and incidentals expenses necessary to complete the work.

Item 4.09 Supply and Placement 3500 psi Concrete for Slope Covering (63.49 Cu.m.)

The quantity to be paid for shall be the actual volume in cubic meters of 3,500 PSI concrete to be supplied and placed for slope covering in accordance with the plans and specifications and accepted by the Engineer. The contract unit price shall be full compensation for furnishing all materials, labor, equipment, tools and incidentals expenses necessary to complete the work.

Item 4.10 Fabricate and Install RSB for Item No. 4.11 (809.86kgs.)

The quantity to be paid for shall be actual weight in kilograms of RSB to be fabricated and installed for Item 4.11 in accordance with the plans and specifications and accepted by the Engineer. The contract unit price shall be full compensation for furnishing all materials, labor, equipment, tools and incidentals expenses necessary to complete the work.

Item 4.11 Supply and Placement of 3500 psi Concrete for Concrete Block (Cast in place) Footing (21.00 Cu.m.)

The quantity to be paid for shall be the actual volume in cubic meters of 3,500 PSI concrete to be supplied and placed for concrete block (cast in place) footing in accordance with the plans and specifications and accepted by the Engineer. The contract unit price shall be full compensation for furnishing all materials, labor, equipment, tools and incidentals expenses necessary to complete the work.

Item 4.12 Chipping of Existing Curb (9.63 Cu.m.)

The quantity to be paid for shall be actual volume in cubic meters of in accordance with the plans and specifications and existing curb to be chipped in accordance with the plans and specifications and accepted by the Engineer. The contract unit price shall be full compensation for furnishing all materials, labor, equipment, tools and incidentals expenses necessary to complete the work.

Item 4.13 Fabricate and Install RSB for Item No. 4.14 (1,657.01 kgs.)

The quantity to be paid for shall be actual weight in kilograms of RSB to be fabricated and installed for item 4.04 in accordance with the plans and specifications and accepted by the Engineer. The contract unit price shall be full compensation for furnishing all materials, labor, equipment, tools and incidentals expenses necessary to complete the work.

Item 4.14 Supply and Placement of 3500 PSI Concrete for Wave Deflector (30.00 Cu.m.)

The quantity to be paid for shall be actual volume in cubic meters of 3,500 PSI concrete to be supplied and placed for wave in accordance with the plans and specifications and accepted by the Engineer. The contract unit price shall be full compensation for furnishing all materials, labor, equipment, tools and incidentals expenses necessary to complete the work.

BILL NO. V – REPAIR OF R.C. PIER

Item 5.01 Removal of Rubber Dock Fenders & Mooring Bollards (9.00 units)

The quantity to be paid for shall be actual number in units of Rubber Dock Fenders and Mooring Bollards to be removed in accordance with the plans and specifications and accepted by the Engineer. The contract unit price shall be full compensation for furnishing all materials, labor, equipment, tools and incidentals expenses necessary to complete the work.

Item 5.02 Demolition and Disposal of Curbs, Bollard Base, Fender Block, RC Deck, RC Beams and Pile Caps (94.35 Cu.m.)

The quantity to be paid for shall be actual volume in cubic meters of Curbs, Bollard Base, Fender Block, RC Deck, RC Beams and Pile Caps to be demolished and disposed in accordance with the plans and specifications and accepted by the Engineer. The contract unit price shall be full compensation for furnishing all materials, labor, equipment, tools and incidentals expenses necessary to complete the work.

Item 5.03 Supply and Install Steel Reinforcement for Pile Caps, Beams, Deck, Bollard Base, Fender Blocks, Curtain Wall and Curbs (18,439.10 Kgs.)

The quantity to be paid for shall be actual weight in kilograms of steel reinforcement to be supplied and installed for Pile Caps, Beams, Deck, Bollard Base, Fender Blocks, Curtain Wall and Curbs in accordance with the plans and specifications and accepted by the Engineer. The contract unit price shall be full compensation for furnishing all materials, labor, equipment, tools and incidentals expenses necessary to complete the work.

Item 5.04 Supply and Placement of 3500 psi Concrete for Pile Caps, Beams, Deck, Bollard Base, Fender Blocks, Curtain Wall and Curbs (103.69 Cu.m.)

The quantity to be paid for shall be actual volume in cubic meters of 3500 psi concrete to be supplied and placed for pile caps, beams, deck, bollard base, fender blocks, curtain wall and curbs in accordance with the plans and specifications and accepted by the Engineer. The contract unit price shall be full compensation for furnishing all materials, labor, equipment, tools and incidentals expenses necessary to complete the work.

Item 5.05 Supply and Install Rubber Dock Fenders, V400 x 1000, including Accessories (5.00 Sets)

The quantity to be paid for shall be number in sets of Rubber Dock Fenders, V400 x 1000, including accessories to be supplied and installed in accordance with the plans and specifications and accepted by the Engineer. The contract unit price shall be full compensation for furnishing all materials, labor, equipment, tools and incidentals expenses necessary to complete the work.

**Item 5.06 Supply and Install 25T T-Head Cast Iron Mooring Bollard,
including Accessories (4.00 Sets)**

The quantity to be paid for shall be number in sets of 25T T-Head Cast Iron Mooring Bollard, including accessories to be supplied and installed in accordance with the plans and specifications and accepted by the Engineer. The contract unit price shall be full compensation for furnishing all materials, labor, equipment, tools and incidentals expenses necessary to complete the work.

**Item 5.07 Supply and Install Edge Protection, 100mm x 100mm x 10mm
Galvanized Angle Bar (4.00 Sets)**

The quantity to be paid for shall be number in sets of Edge Protection, 100mm x 100mm x 10mm Galvanized Angle Bar, including accessories to be supplied and installed in accordance with the plans and specifications and accepted by the Engineer. The contract unit price shall be full compensation for furnishing all materials, labor, equipment, tools and incidentals expenses necessary to complete the work.

BILL NO. VI – REPAIR OF RETAINING WALL

Item 6.01 Demolition and Disposal of Damaged Retaining Wall (9.00 cu.m.)

The quantity to be paid for shall be actual volume in cubic meters of damaged retaining wall to be demolished and removed in accordance with the plans and specifications and accepted by the Engineer. The contract unit price shall be full compensation for furnishing all materials, labor, equipment, tools and incidentals expenses necessary to complete the work.

**Item 6.02 Extraction of Secondary Rocks affected by foundation of
Retaining wall Removal (83.05 cu.m.)**

The quantity to be paid for shall be actual volume in cubic meters of secondary rock affected by foundation of retaining wall to be removed in accordance with the plans and specifications and accepted by the Engineer. The contract unit price shall be full compensation for furnishing all materials, labor, equipment, tools and incidentals expenses necessary to complete the work.

**Item 6.03 Supply and Install Steel Reinforcement for Footing
and Stem of R.C. Wall (1,812.41 kgs.)**

The quantity to be paid for shall be actual weight in kilograms of steel reinforcement to be supplied and installed for footing and stem of R.C. Wall in accordance with the plans and specifications and accepted by the Engineer. The contract unit price shall be full compensation for furnishing all materials, labor, equipment, tools and incidentals expenses necessary to complete the work.

**Item 6.04 Supply and Placement of 3,500 psi Concrete for Footing
and Stem of RC Wall (28.77 Cu.m.)**

The quantity to be paid for shall be actual volume in cubic meters of 3,500psi concrete to be supplied and placed for footing and stem of R.C. Wall in accordance with the plans and specifications and accepted by the Engineer. The contract unit price shall

be full compensation for furnishing all materials, labor, equipment, tools and incidentals expenses necessary to complete the work.

BILL NO. VII – REMOVAL OF SUNKEN LOGS/DERELICTS AROUND THE PERIPHERY OF R.C. PIER

Item 7.01 Removal of Sunken Logs (1.00 Lot)

The quantity to be paid for shall be the whole lot of sunken logs to be removed in accordance with the plans and specifications and accepted by the Engineer. The contract unit price shall be full compensation for furnishing all materials, labor, equipment, tools and incidentals expenses necessary to complete the work.

BILL NO. VIII – CLEARING WORKS

Item 8.01 Clear, Clean and Dispose Construction Wastes and Debris (1.00 Lot)

The quantity to be paid for shall be the whole lot of clearing, cleaning and disposal works of construction wastes and debris in accordance with the plans and specifications and accepted by the Engineer. The contract unit price shall be full compensation for furnishing all materials, labor, equipment, tools and incidentals expenses necessary to complete the work.

Item 8.02 Transport of Salvage Materials (Bollards, RDFs, Steel Bars) from Site to Baseport (1.00 Lot)

The quantity to be paid for shall be the whole lot of salvage materials (Bollards, RDFs, Steel Bars) to be transported from Site to Baseport in accordance with the plans and specifications and accepted by the Engineer. The contract unit price shall be full compensation for furnishing all materials, labor, equipment, tools and incidentals expenses necessary to complete the work.

MAY 15 2020



ENGINEERING CIRCULAR NO. 41 2020

FOR THE MANAGER, PCMD
ALL PORT MANAGERS
CONCERNED CONTRACTORS

FROM THE ASSISTANT GENERAL MANAGER,
ENGINEERING OFFICE

SUBJECT SAFETY GUIDELINES FOR THE IMPLEMENTATION OF
ALL PPA (CAPEX & RM) AND DOTr TOURISM AND
SOCIAL REFORM PROJECTS DURING THE COVID-19
PUBLIC HEALTH CRISIS

Pursuant to the Proclamation No. 929, series of 2020 issued by President Rodrigo Roa Duterte, declaring a State of Calamity throughout the Philippines due to the Coronavirus Disease 2019 (COVID-19) and in view of the extended implementation of Enhanced Community Quarantine (ECQ) and General Community Quarantine (GCQ) in the identified areas, the following guidelines, in addition to the existing safety standards approved by the DOLE and also to the PPA Memorandum Circular No. 18-2020, are hereby directed to be implemented in all on-going PPA infrastructure projects including the DOTr Tourism and Social Reform projects:

1. Only persons from Twenty-One (21) to Fifty-Nine (59) years of age, without pre-existing health conditions, such as, but not limited to immunodeficiency, comorbidities or other health risk and who did not come in contact with someone with COVID-19 shall be allowed to be included in the workforce for areas under ECQ and GCQ.
2. The Contractor shall provide for their personnel/workers the necessary welfare facilities and amenities, such as employees' quarters for board and lodging for the project area covered by the ECQ and GCQ, otherwise, prior to deployment, prescribed procedures shall be conducted at every instance of re-entry.
3. Adequate food, potable drinking water, disinfectants shall be made available by the Contractors for their in-house personnel/worker during the period of ECQ/GCQ.
4. Compliance to social distancing, proper hygiene and mandatory wearing of face masks and other protective personal equipment shall be ensured for all on-going projects as precautionary measures to avoid and contain the spread of COVID-19 in the work place.

5. Field Offices, employees' quarters, bunkhouses and other common areas shall be maintained to ensure cleanliness and daily disinfection of said areas must be conducted accordingly.
6. Contractors shall provide disinfection facilities such as handwashing station, foot bath and others to be placed at various locations of all on-going projects.
7. Contractors shall ensure that their projects are in compliance with the DOLE D.O. No. 13 series of 1998. Personnel and workers shall be provided with the supply of vitamins particularly Vitamin C and other over the counter medicines, quarantine facilities and oxygen tanks for emergency purposes.
8. Safety Officer of the Contractor shall regularly conduct briefing on the information regarding COVID-19 construction protocols on top of other safety requirements.
9. As preventive measure, daily monitoring of the pre and post work health conditions of workers shall be undertaken by the Contractor's health/safety officer particularly the temperature, blood pressure and exposure monitoring. Personnel with symptoms relative to COVID-19 shall be immediately isolated and quarantined for fourteen (14) days and if necessary, brought to the DOH COVID-19 treatment facility under strict confidentiality/privacy.
10. Daily health monitoring report shall be prepared by the Safety Officer and to be submitted to the assigned PPA Project Engineer/Port Engineer.
11. Proper protocols in accordance with the DTI and DOLE Interim Guidelines and the Local Government Unit policy on work place prevention and control of COVID-19 shall likewise be strictly observed.
12. Daily work activities shall be under strict monitoring by the Safety Officer to ensure compliance with safety standards and quarantine protocols.
13. Sharing of construction and office equipment is discouraged. However, if it cannot be avoided, disinfection of equipment in between transfer shall be conducted.
14. All materials and equipment brought inside the project site shall be disinfected, as much as possible.
15. Non-essential personnel, visitors and general public shall be restricted to enter the project site. All personnel entering the construction site premises on a temporary basis (e.g. Delivery truck drivers, inspectors, etc) shall be properly logged and checked for symptoms. Gatherings, liquors, and/or merry-making are strictly prohibited in the project site.

16. PPA Port/Resident Engineer shall ensure strict compliance to DOLE D.O No. 13, series of 1998 and implementation of the mentioned COVID -19 precautionary measures in the work place.
17. Clustered and staggered deployment of employees within the construction site shall be observed to minimize personnel contact.
18. Contractors shall submit to the implementing unit the inventory of work activities including the proposed sequencing of activities to be followed and undertaken to comply to the required social distancing. Break times shall be conducted in a staggered manner.

For strict compliance.

CONSTANTE T. FARIÑAS, JR.



Section IX.
***Checklist of Technical
and Financial Documents***

Checklist of Technical and Financial Documents

I. TECHNICAL COMPONENT ENVELOPE

Class "A" Documents

Legal Documents

- (a) Valid PhilGEPS Registration Certificate (Platinum Membership) (all pages);
or
- (b) Registration certificate from Securities and Exchange Commission (SEC), Department of Trade and Industry (DTI) for sole proprietorship, or Cooperative Development Authority (CDA) for cooperatives or its equivalent document;
and
- (c) Mayor's or Business permit issued by the city or municipality where the principal place of business of the prospective bidder is located, or the equivalent document for Exclusive Economic Zones or Areas;
and
- (d) Tax clearance per E.O. No. 398, s. 2005, as finally reviewed and approved by the Bureau of Internal Revenue (BIR).

Technical Documents

- (e) Statement of the prospective bidder of all its ongoing government and private contracts, including contracts awarded but not yet started, if any, whether similar or not similar in nature and complexity to the contract to be bid; and
- (f) Statement of the bidder's Single Largest Completed Contract (SLCC) similar to the contract to be bid, except under conditions provided under the rules;
and
- (g) Philippine Contractors Accreditation Board (PCAB) License;
or
Special PCAB License in case of Joint Ventures;
and registration for the type and cost of the contract to be bid; and
- (h) Original copy of Bid Security. If in the form of a Surety Bond, submit also a certification issued by the Insurance Commission;
or
Original copy of Notarized Bid Securing Declaration; and
- (i) Project Requirements, which shall include the following:
 - a. Organizational chart for the contract to be bid;
 - b. List of contractor's key personnel (e.g., Project Manager, Project Engineers, Materials Engineers, and Foremen), to be assigned to the contract to be bid, with their complete qualification and experience data;
 - c. List of contractor's major equipment units, which are owned, leased, and/or under purchase agreements, supported by proof of ownership or certification of availability of equipment from the equipment lessor/vendor for the duration of the project, as the case may be; and
- (j) Original duly signed Omnibus Sworn Statement (OSS);
and if applicable, Original Notarized Secretary's Certificate in case of a corporation, partnership, or cooperative; or Original Special Power of Attorney of all members of the joint venture giving full power and authority to its officer to sign the OSS and do acts to represent the Bidder.

Financial Documents

- (k) The prospective bidder's audited financial statements, showing, among others, the prospective bidder's total and current assets and liabilities, stamped "received" by the BIR or its duly accredited and authorized institutions, for the preceding calendar year which should not be earlier than two (2) years from the date of bid submission; and

- (f) The prospective bidder's computation of Net Financial Contracting Capacity (NFCC).

Class "B" Documents

- (m) If applicable, duly signed joint venture agreement (JVA) in accordance with RA No. 4566 and its IRR in case the joint venture is already in existence;
or
duly notarized statements from all the potential joint venture partners stating that they will enter into and abide by the provisions of the JVA in the instance that the bid is successful.

II. FINANCIAL COMPONENT ENVELOPE

- (n) Original of duly signed and accomplished Financial Bid Form; **and**

Other documentary requirements under RA No. 9184

- (o) Original of duly signed Bid Prices in the Bill of Quantities; **and**
- (p) Duly accomplished Detailed Estimates Form, including a summary sheet indicating the unit prices of construction materials, labor rates, and equipment rentals used in coming up with the Bid; **and**
- (q) Cash Flow by Quarter.



Section X.
Bidding Form

Bid Form for the Procurement of Infrastructure Projects

[shall be submitted with the Bid]

BID FORM

Date : _____

Project Identification No. : _____

To: *[name and address of Procuring Entity]*

Having examined the Philippine Bidding Documents (PBDs) including the Supplemental or Bid Bulletin Numbers *[insert numbers]*, the receipt of which is hereby duly acknowledged, we, the undersigned, declare that:

- a. We have no reservation to the PBDs, including the Supplemental or Bid Bulletin, for the Procurement Project: *[insert name of contract]*;
- b. We offer to execute the Works for this Contract in accordance with the PBDs;
- c. The total price of our Bid in words and figures, excluding any discounts offered below is: *[insert information]*;
- d. The discounts offered and the methodology for their application are: *[insert information]*;
- e. The total bid price includes the cost of all taxes, such as, but not limited to: *[specify the applicable taxes, e.g. (i) value added tax (VAT), (ii) income tax, (iii) local taxes, and (iv) other fiscal levies and duties]*, which are itemized herein and reflected in the detailed estimates;
- f. Our Bid shall be valid within the a period stated in the PBDs, and it shall remain binding upon us at any time before the expiration of that period;
- g. If our Bid is accepted, we commit to obtain a Performance Security in the amount of *[insert percentage amount]* percent of the Contract Price for the due performance of the Contract, or a Performance Securing Declaration in lieu of the the allowable forms of Performance Security, subject to the terms and conditions of issued GPPB guidelines¹ for this purpose;
- h. We are not participating, as Bidders, in more than one Bid in this bidding process, other than alternative offers in accordance with the Bidding Documents;
- i. We understand that this Bid, together with your written acceptance thereof included in your notification of award, shall constitute a binding contract between us, until a formal Contract is prepared and executed; and
- j. We understand that you are not bound to accept the Lowest Calculated Bid or any other Bid that you may receive.
- k. We likewise certify/confirm that the undersigned, is the duly authorized representative of the bidder, and granted full power and authority to do, execute and perform any and all acts necessary to participate, submit the bid, and to sign and execute the ensuing contract for the *[Name of Project]* of the *[Name of the Procuring Entity]*;
- l. We acknowledge that failure to sign each and every page of this Bid Form, including the Bill of Quantities, shall be a ground for the rejection of our bid.

¹ currently based on GPPB Resolution No. 09-2020

Name: _____

Legal Capacity: _____

Signature: _____

Duly authorized to sign the Bid for and behalf of: _____

Date: _____

**STATEMENT OF ALL ON-GOING GOVERNMENT AND PRIVATE CONTRACTS
INCLUDING CONTRACTS AWARDED BUT NOT YET STARTED, WHETHER SIMILAR OR NOT SIMILAR IN NATURE**

Name of the Contract or Title of the Project [1]	Owner's Name, Address, and Telephone Nos.	Nature/ Scope of Work [2]	Contractor's Role (in percentage) [3]	Total Contract Value at Award			Date of Award [4]	Value of Outstanding Works	Estimated Time of Completion	AS OF		Contract Duration	
				Award	Project Completion	Escalated Value to Present Prices				% of Accomplishment [5]		Start	Completed
										Planned	Actual		
a) Government Contracts/Projects I. On-going II. Awarded but not yet started													
b) Private Contracts/Projects I. On-going II. Awarded but not yet started													

NOTE:

- 1) As appearing or defined in the contract entered/executed by the parties
- 2) With special reference to the Scope of Works as described/enumerated in the advertised invitation to Bid
- 3) Indicate whether as Sole Contractor, Sub-Contractor or Member in a Joint Venture / Consortium
- 4) Indicate the FOREX used if Contract Value is expressed in a currency other than the Philippine Peso. Specify the "Escalation Factor" used to escalate the Contract Value from Completion date to the advertisement date of the invitation to Bid per section 23.11.2(3) of R.A. 9154
- 5) State month and Year.

This Statement shall be supported by

- a) Notice of Award and/or Contract
- b) Notice to Proceed

Name of Firm/Applicant

Authorized Signing Official

Date

STATEMENT OF SINGLE LARGEST COMPLETED CONTRACT (SLCC) SIMILAR TO THE CONTRACT TO BE BID

Name of the Contract or Title of the Project ^{a)} [1]	Owner's Name, Address, and Telephone Numbers [2]	Nature/Scope of Work ^{b)} [3]	Contractor's Role (In percentage) ^{c)} [4]	Total Contract Value (in Pesos)		Date of Award ^{d)} [7]	Contract Duration ^{e)}	
				at Project Completion [5]	at Adjusted Value to Present Prices ^{d)} [6]		Start [8]	Completed [9]

NOTE:

1. The prospective bidder must have completed an SLCC that is similar to the contract to be bid, and whose value, adjusted to current prices using the PBA consumer price indices, must be at least fifty (50%) of the ABC to be bid.
2. The Statement shall be supported by:
 - a) Notice of Award and / or Notice to Proceed
 - b) Project Owner's Certificate of Final acceptance issued by the owner other than the Contractor or Constructor's Performance Evaluation System (CPES) Final Rating, which must be at least satisfactory.
 - c) Recapitulation of Bill of Quantities

Name of Firm/Applicant

Authorized Signing Official

Date

EXPERIENCE RECORD ON SIMILARLY COMPLETED PROJECT

Name of Contract to be Bid: Repair of Damaged R.C. Pier, Concrete Pavement Approach, Slope Protection, Back-up Area and Removal of Sunken Derelicts/Logs, Port of Rizal, Brgy. Puntabaja, Rizal, Palawan

Name of Single Largest Completed Contract with the same Major Categories Of Work as the Contract to be Bid (To be filled-up by Prospective Bidder): _____

Major Categories of Work [1]	Unit of Measure [3]	Quantity [4]	Similar Completed Contract of the Prospective Bidder (To Be filled-up by the Prospective Bidder)		
			Similar Major Categories of Work	Unit of Measure	Quantity
1. DEMOLITION WORKS	Cu.m.	62.00			
2. ROCK WORKS	Cu.m.	182.00			
3. SUPPLY, SPREAD & COMPACT AGGREGATE BASE COURSE	Cu.m.	18.00			
4. REINFORCING STEEL BARS	Kgs.	17,176.00			
5. CONCRETE WORKS	Cu.m.	182.00			
6. SUPPLY & INSTALL ROF	unit	3.00			
7. SUPPLY & INSTALL MOORING BOLLARD	unit	2.00			

NOTE: 1) Submit the Certificate of Completion/Certificate of Acceptance by the project owner, Final Recapitulation/Bill of Quantities and/or Constructor Performance Evaluation System (CPES) ratings, 1st, 2nd, & Final visit (if applicable). Project with no Certificate of Completion and Recapitulation/Bill of Quantities shall not be considered.

2) The Owner's Certificate of Final Acceptance; or the Constructors Performance Evaluation Summary (CPES) Final Rating and/or the Certificate of Completion, must be satisfactory.

Name of Firm/Applicant

Authorized Signing Official

Date

FINANCIAL DATA AND REQUIREMENTS

- A. The prospective bidder's audited Financial Statements, showing, among others, the prospective bidder's total and current assets and liabilities, stamped "RECEIVED" by Bureau of Internal Revenue (BIR), or its duly accredited and authorized institutions, for the preceding calendar year which should not be earlier than two (2) years from the date of bid submission.

[1]

[2]

		Year :
1.	Total Assets	
2.	Current Assets	
3.	Total Liabilities	
4.	Current Liabilities	
5.	Net Worth (1-3)	
6.	Net Working Capital (2-4)	

- B. The computation of the bidders Net Financial Contracting Capacity (NFCC) must be at least equal to the approved budget for the contract to be bid, computed based on the above data, using the following formula:

NFCC = [(current assets - current liabilities) (15)] *minus* the value of all outstanding or uncompleted portions of the project under ongoing contracts, including awarded contracts yet to be started, coinciding with the contract to be bid

NFCC = _____

Attached herewith are certified true copies of the audited financial statements stamped received by the BIR or BIR authorized collecting agent for the latest/immediately preceding calendar year.

Name of Prospective Bidder-Firm

Signature over Printed Name of Authorized Signing Official

Designation

Date: _____

NOTE : *If prospective bidder is a Partnership or Joint Venture, each member-firm of the Joint Venture shall submit separate financial statements.*

KEY PERSONNEL TO BE ASSIGNED TO THE CONTRACT TO BE BID

Following are the key personnel that I will assign to the project if awarded the contract. Attached are their qualification and experience data and certified true copies of their PRC IDs, certificates of accreditation, etc.

Name of Contract to be Bid: _____

	Project Manager [1]	Project Engineer [2]	Materials Engineer [3]	Foreman [4]	Construction Safety and Health Officer [5]
1. NAME					
2. ADDRESS					
3. DATE OF BIRTH					
4. CITIZENSHIP					
5. CIVIL STATUS					
6. EDUCATION					
ELEMENTARY					
Name and Location of School Year Graduated					
HIGH SCHOOL					
Name and Location of School Year Graduated					
COLLEGE					
Name and Location of School Year Graduated					
7. PRC LICENSE No.					
8. TIN (Tax Identification No.)					
9. SSS No.					

Name of Prospective Bidder-Firm

Signature over Printed Name of Authorized Signing Official

Date

Designation

NOTE : *Attach complete qualification and experience data of all Key Personnel including certified copies of their valid DPWH certificate of accreditation for Materials Engineer, PRC ID's for the Project Engineer and Certificate of Training for the Construction Safety and Health Officer issued by the DOLE Accredited Training. Failure to attach the said documents is ground for disqualification.*

BIODATA OF (Position of Key Personnel)

[Give detailed information of the Key Personnel who are assigned as full-time Project Manager, Project Engineer, Materials Engineer and Foreman for the project to be bid. Each Key Personnel must fill-up this form.]

1. Name : _____
2. Date of Birth : _____
3. Nationality : _____
4. Education and Degrees : _____
5. Specialty : _____
6. Registration : _____
7. Length of Service with the Firm : _____ Years, from _____ (month) _____ (year) to _____ (month) _____ (year)
8. Total Years of Experience including previous employment : _____
9. If Item 7 is less than ten (10) years, give name and length of service with previous employers for a ten (10)-year period (*attached additional sheet/s if necessary*) :

Name and Address of Employer

Length of Service

10. Experience: (see next page)

BIO DATA OF _____ (Continuation)

10. Experience: (This should cover the past ten (10) years of experience. Attached as many pages as necessary to show involvement of personnel in the projects using the format below.)

Name of Company/Firm	Name and Address of Owner of Company/Firm	Indicate the features of project (particulars of the project components and any other particular interest connected with the project)	Contract Amount (in Philippine Currency)	Position	Structures for which the employee/ personnel was responsible	Assignment Period	
						From	To

(Name and Signature of Employee/Personnel)

It is hereby certified that the above personnel can be assigned to this project, if the contract is awarded to our company.

(Place and Date)

(Signature Over Printed Name of Authorized Signatory of the Bidder-Firm)

Designation

(For equipment units owned by the Bidder)

CERTIFICATION OF AVAILABILITY OF EQUIPMENT

This is to certify that I have the following owned equipment units which shall be used exclusively for the duration of the project _____ *(name of contract to be bid)* _____

if awarded the contract, to wit:

<u>No. of Units</u>	<u>Name/Description of Equipment</u>	<u>Performance Capacity</u>
---------------------	--------------------------------------	-----------------------------

IN WITNESS WHEREOF, I have hereunto set my hand this _____ day of _____ 2021 at _____, Philippines.

(Signature over printed name of Bidder)

(Position/Designation in the Company)

(Name of Company of Bidder)

Affiant

ACKNOWLEDGEMENT

SUBSCRIBED AND SWORN to before me this _____ day of _____, 20____ affiant exhibiting to me his/her Community Tax Certificate No. _____ issued on _____ at _____, Philippines.

Doc. No. _____
Page No. _____
Book No. _____
Series of _____

NOTARY PUBLIC

(For equipment units under Lease)

CERTIFICATION OF AVAILABILITY OF EQUIPMENT

This is to certify that I have the following owned equipment units which are available for lease to (name of bidder) and which shall be exclusively used for the duration of the project (name of contract to be bid), to wit

No. of Units Name/Description of Equipment Performance Capacity Rental/Day

The undersigned shall execute with (name of bidder) the corresponding contract of lease for the above-mentioned equipment upon award of the contract to the latter.

IN WITNESS WHEREOF, I have hereunto set my hand this ____ day of _____ 2017 at _____, Philippines

(Signature over printed name of Lessor)
(Position/Designation in the Company)
(Name of Lessor's
Affiant

CONFORME:

(Signature over printed name of Bidder)
(Position/Designation in the Company)
(Name of Bidder's Co

ACKNOWLEDGEMENT

SUBSCRIBED AND SWORN to before me this ____ day of _____, 20__ affiant exhibiting to me his/her Community Tax Certificate No. _____ issued on _____ at _____, Philippines.

Doc. No. _____
Page No. _____
Book No. _____
Series of _____

NOTARY PUBLIC

(For equipment units under Purchase Agreement)

CERTIFICATION OF AVAILABILITY OF EQUIPMENT

This is to certify that I have the following owned equipment units which are available for sale to/purchase by _____ (name of bidder) _____ and which shall be exclusively used for the duration of the project _____ (name of contract to be bid) _____, to wit:

<u>No. of Units</u>	<u>Name/Description of Equipment</u>	<u>Performance Capacity</u>	<u>Amount</u>
---------------------	--------------------------------------	-----------------------------	---------------

The undersigned shall execute with _____ (name of bidder) _____ the corresponding purchase agreement/deed of sale for the above-mentioned equipment upon award of the contract to the latter.

IN WITNESS WHEREOF, I have hereunto set my had this _____ day _____ 2021 at _____, Philippines.

(Signature over printed name of Vendor)

(Position/Designation in the Company)

(Name of Vendor)

Affiant

CONFORME:

(Signature over printed name of Bidder)

(Position /Designation in the Company)

(Name of Bidder)

ACKNOWLEDGEMENT

SUBSCRIBED AND SWORN to before me this _____ day of _____, 20__ affiant exhibiting to me his/her Community Tax Certificate No. _____ issued on _____ at _____, Philippines.

Doc. No. _____
Page No. _____
Book No. _____
Series of _____

NOTARY PUBLIC

CONTRACT OF LEASE OF EQUIPMENT

KNOW ALL MEN BY THESE PRESENTS:

This contract made and entered into this _____ in
_____ by and between:

_____, a company duly organized and existing under and
by the virtue of Laws of the Republic of the Philippines, with Postal address at
_____; represented in this Act by its President /
General Manager, _____ hereinafter referred to as
the LESSOR.

- AND -

_____, a company duly organized and existing under and
by the virtue of Laws of the Republic of the Philippines, with Postal address at
_____; represented in this Act by its President /
General Manager, _____ hereinafter referred to as
the LESSEE.

WITNESSETH

Whereas, the Lessor represents that it is the Owner/Legal possessor of below
described construction equipment hereinafter referred to as the EQUIPMENT.

Whereas, the LESSEE being engaged in the construction activities, is in need of the
EQUIPMENT and has satisfied himself that the same is suitable for the proposed project:

Whereas, on offer and acceptance made by one to the other, the parties hereby
agree to execute the Contract of Lease of Equipment under the terms and conditions set
forth;

Whereas, the Contract of Lease of Equipment shall be executed after the award of
the above-mentioned project to the LESSEE and the contract shall be in effect until such
time that the contractor is authorized by the Philippine Ports Authority to pull out the said
equipment

Now, therefore, for and in consideration of the foregoing premises, the LESSOR
hereby leases and the LESSEE accepts the lease of the following EQUIPMENT, to wit :

<u>DESCRIPTION</u>	<u>PERFORMANCE CAPACITY</u>	<u>RATE PER HOUR (Php) or RATE PER DAY</u>
.....
.....
.....
.....

TERMS AND CONDITIONS:

1. In case wherein the equipment is utilized below two (2) hours (or days), a minimum of one (1) hour (or day) per day shall be charged to the LESSEE.
2. Lease contract shall commence when the equipment leaves the LESSOR'S yard and shall terminate upon the return of the equipment by the LESSEE to the LESSOR'S yard.
3. LESSEE shall pick-up the equipment and its operators at LESSOR'S yard. Upon termination of works, the lessee shall demobilize all units within one week. LESSEE shall

pay for each unit an equivalent of one (1) hour (or day) rental for every day of delayed demobilization.

4. Fuel, oil and lubricants to be supplied by the LESSEE but for the account of the LESSOR.
5. The equipment and accessories contracted shall be under the supervision and responsibility for the safekeeping and scope of work of the equipment and accessories or as required by the LESSOR.
6. Equipment operator(s), mechanics and servicemen shall be provided by and for the account of the LESSOR.
7. MOBILIZATION, provided for LESSEE'S account, per equipment hour (or day) basis.
8. DEMOBILIZATION, for LESSEE'S account, per equipment hour (or day) basis.

IN WITNESS THEREFORE, both parties agreed and hereto have subscribed their names:

LESSOR:

LESSEE:

by: _____

by: _____

WITNESSED BY:

REPUBLIC OF THE PHILIPPINES)
CITY/MUNICIPALITY OF _____) S. S.

ACKNOWLEDGEMENT

BEFORE ME, A NOTARY PUBLIC, personally appeared the following persons:

	NAME	RES.CERT. #	DATE	PLACE
1.	_____ (Lessor)	_____	_____	_____
2.	_____ (Lessee)	_____	_____	_____

are known to me to be the same persons who executed and signed the foregoing CONTRACT OF LEASE OF EQUIPMENT, acknowledged to me that the same are their true and voluntary act and deed of the company they each represent.

WITNESS MY HAND AND NOTARIAL SEAL on this _____ at _____, Philippines.

Doc. No. _____
Page No. _____
Book No. _____
Series of _____

NOTARY PUBLIC

AFFIDAVIT OF SITE INSPECTION

I, _____, of legal age, Filipino, married, and residing at _____
after having been duly sworn to in accordance with law, hereby depose and say:

1. That I am the _____ of _____
with principal address at _____
2. That I have inspected the project site for the _____
on _____
3. That I have fully determined the geographical and physical conditions of the project site and its environ, including the socio-political and peace and order condition of the barangay, municipality and province where the project is located;
4. That I am fully aware of the laws and ordinances pertaining to project implementation in the barangay, municipality and province where the project is located, as well as the rules and regulations of other government agencies concerning project implementation in the area where the project is located;
5. That I am executing this affidavit to attest to the truth of the foregoing facts and as part of the post-qualification documentary requirements for the aforementioned project.

IN WITNESS WHEREOF, I have hereunto set my hand this ____ day of _____

(Affiant's signature over printed name)

SUBSCRIBED AND SWORN TO before me this _____, affiant exhibiting to me his/her Community Tax Certificate No. _____ issued on _____ at _____, Philippines.

Doc. No. _____

Page No. _____

Book No. _____

Series of 2021

Omnibus Sworn Statement (Revised)
[shall be submitted with the Bid]

REPUBLIC OF THE PHILIPPINES)
CITY/MUNICIPALITY OF _____) S.S.

AFFIDAVIT

I, [Name of Affiant], of legal age, [Civil Status], [Nationality], and residing at [Address of Affiant], after having been duly sworn in accordance with law, do hereby depose and state that:

1. *[Select one, delete the other:]*

[If a sole proprietorship:] I am the sole proprietor or authorized representative of [Name of Bidder] with office address at [address of Bidder];

[If a partnership, corporation, cooperative, or joint venture:] I am the duly authorized and designated representative of [Name of Bidder] with office address at [address of Bidder];

2. *[Select one, delete the other:]*

[If a sole proprietorship:] As the owner and sole proprietor, or authorized representative of [Name of Bidder] I have full power and authority to do, execute and perform any and all acts necessary to participate, submit the bid, and to sign and execute the ensuing contract for [Name of the Project] of the [Name of the Procuring Entity], as shown in the attached duly notarized Special Power of Attorney;

[If a partnership, corporation, cooperative, or joint venture:] I am granted full power and authority to do, execute and perform any and all acts necessary to participate, submit the bid, and to sign and execute the ensuing contract for [Name of the Project] of the [Name of the Procuring Entity], as shown in the attached [state title of attached document showing proof of authorization (e.g., duly notarized Secretary's Certificate, Board/Partnership Resolution, or Special Power of Attorney, whichever is applicable)];

3. [Name of Bidder] is not "blacklisted" or barred from bidding by the Government of the Philippines or any of its agencies, offices, corporations, or Local Government Units, foreign government/foreign or international financing institution whose blacklisting rules have been recognized by the Government Procurement Policy Board, by itself or by relation, membership, association, affiliation, or controlling interest with another blacklisted person or entity as defined and provided for in the Uniform Guidelines on Blacklisting;

4. Each of the documents submitted in satisfaction of the bidding requirements is an authentic copy of the original, complete, and all statements and information provided therein are true and correct;

5. [Name of Bidder] is authorizing the Head of the Procuring Entity or its duly authorized representative(s) to verify all the documents submitted;

6. *[Select one, delete the rest:]*

[If a sole proprietorship:] The owner or sole proprietor is not related to the Head of the Procuring Entity, members of the Bids and Awards Committee (BAC), the Technical Working Group, and the BAC Secretariat, the head of the Project Management Office or the end-user unit, and the project consultants by consanguinity or affinity up to the third civil degree;

[If a partnership or cooperative:] None of the officers and members of [Name of Bidder] is related to the Head of the Procuring Entity, members of the Bids and Awards Committee

(BAC), the Technical Working Group, and the BAC Secretariat, the head of the Project Management Office or the end-user unit, and the project consultants by consanguinity or affinity up to the third civil degree;

[If a corporation or joint venture:] None of the officers, directors, and controlling stockholders of *[Name of Bidder]* is related to the Head of the Procuring Entity, members of the Bids and Awards Committee (BAC), the Technical Working Group, and the BAC Secretariat, the head of the Project Management Office or the end-user unit, and the project consultants by consanguinity or affinity up to the third civil degree;

7. *[Name of Bidder]* complies with existing labor laws and standards; and
8. *[Name of Bidder]* is aware of and has undertaken the responsibilities as a Bidder in compliance with the Philippine Bidding Documents, which includes:
 - a. Carefully examining all of the Bidding Documents;
 - b. Acknowledging all conditions, local or otherwise, affecting the implementation of the Contract;
 - c. Making an estimate of the facilities available and needed for the contract to be bid, if any; and
 - d. Inquiring or securing Supplemental/Bid Bulletin(s) issued for the *[Name of the Project]*.
9. *[Name of Bidder]* did not give or pay directly or indirectly, any commission, amount, fee, or any form of consideration, pecuniary or otherwise, to any person or official, personnel or representative of the government in relation to any procurement project or activity.
10. In case advance payment was made or given, failure to pay or deliver any of the obligations and undertakings in the contract shall be sufficient grounds to constitute criminal liability for Swindling (Estafa) or the commission of fraud with unfaithfulness or abuse of confidence through misappropriating or converting any payment received by a person or entity under an obligation involving the duty to deliver certain goods or services, to the prejudice of the public and the government of the Philippines pursuant to Article 315 of Act No. 3815 s. 1930, as amended, or the Revised Penal Code.

IN WITNESS WHEREOF, I have hereunto set my hand this ___ day of ___, 20__ at _____, Philippines.

[Insert NAME OF BIDDER OR ITS AUTHORIZED REPRESENTATIVE]

[Insert signatory's legal capacity]

Affiant

[Jurat]

[Format shall be based on the latest Rules on Notarial Practice]

Bid Securing Declaration Form

[shall be submitted with the Bid if bidder opts to provide this form of bid security]

REPUBLIC OF THE PHILIPPINES)
CITY OF _____) S.S.

BID SECURING DECLARATION **Project Identification No.: [Insert number]**

To: *[insert name and address of the Procuring Entity]*

I/We, the undersigned, declare that:

1. I/We understand that, according to your conditions, bids must be supported by a Bid Security, which may be in the form of a Bid Securing Declaration.
2. I/We accept that: (a) I/we will be automatically disqualified from bidding for any procurement contract with any procuring entity for a period of two (2) years upon receipt of your Blacklisting Order; and, (b) I/we will pay the applicable fine provided under Section 6 of the Guidelines on the Use of Bid Securing Declaration, within fifteen (15) days from receipt of the written demand by the procuring entity for the commission of acts resulting to the enforcement of the bid securing declaration under Sections 23.1(b), 34.2, 40.1 and 69.1, except 69.1(f), of the IRR of RA No. 9184; without prejudice to other legal action the government may undertake.
3. I/We understand that this Bid Securing Declaration shall cease to be valid on the following circumstances:
 - a. Upon expiration of the bid validity period, or any extension thereof pursuant to your request;
 - b. I am/we are declared ineligible or post-disqualified upon receipt of your notice to such effect, and (i) I/we failed to timely file a request for reconsideration or (ii) I/we filed a waiver to avail of said right; and
 - c. I am/we are declared the bidder with the Lowest Calculated Responsive Bid, and I/we have furnished the performance security and signed the Contract.

IN WITNESS WHEREOF, I/We have hereunto set my/our hand/s this ____ day of [month] [year] at [place of execution].

[Insert NAME OF BIDDER OR ITS AUTHORIZED REPRESENTATIVE]

[Insert signatory's legal capacity]

Affiant

[Jurat]

[Format shall be based on the latest Rules on Notarial Practice]

CONSTRUCTION METHODOLOGY

Name of Project _____

Proposed Project Description _____

Location _____

MINIMUM SCOPE OF CONSTRUCTION METHODOLOGY

1. Demolition Works
2. Rock Works
3. Supply, Spread and Compact Aggregate Base course
4. Reinforcing Steel Bars
5. Concrete Works
6. Supply and Install RDF
7. Supply and Install Mooring Bollard

Notes;

The narrative construction method will guide and familiarize the contractor and the PPA on how the project shall be carried out in accordance with the highest standard of workmanship

The construction method shall be consistent with the Bar Chart / S-Curve Schedule, Equipment Schedule and manpower Schedule.

Signature
(Authorized Signing Official)

MANPOWER SCHEDULE

Name of Project : _____

Proposed Project Description : _____

Location : _____

MANPOWER (Minimum)	CONTRACT DURATION (_____ Calendar Days)																					
	MONTHLY																					
	1	2	3	4	5	6	7	8	9	10	11	12	13	14	15	16	17	18	19	20	21	22
Project Manager																						
Project Engineer																						
Materials Engineer																						
Construction Safety & Health Officer																						
Specify other applicable positions, ie.:																						
-Carpenter																						
-Steelmen																						
-Mason																						
-Electrician																						
-Fitter																						
-Others																						

Signature
(Authorized Signing Official)

CASHFLOW BY QUARTER AND PAYMENT SCHEDULE

Name of Project _____

Proposed Project Description _____

Location _____

Project Duration (days of months)	Payment Schedule (Monthly, in Pesos)	Cash Flow (Quarterly, in Pesos)
TOTAL		

NOTES:

- The cash flow by quarter and payment schedule should be consistent with the Bar Chart and S-curb.
- Payment schedule shall not be more than once a month.

 Signature
 (Authorized Signing Official)

Contract Agreement Form for the Procurement of Infrastructure Projects (Revised)

[not required to be submitted with the Bid, but it shall be submitted within ten (10) days after receiving the Notice of Award]

CONTRACT AGREEMENT

THIS AGREEMENT, made this *[insert date]* day of *[insert month]*, *[insert year]* between *[name and address of PROCURING ENTITY]* (hereinafter called the "Entity") and *[name and address of Contractor]* (hereinafter called the "Contractor").

WHEREAS, the Entity is desirous that the Contractor execute *[name and identification number of contract]* (hereinafter called "the Works") and the Entity has accepted the Bid for *[contract price in words and figures in specified currency]* by the Contractor for the execution and completion of such Works and the remedying of any defects therein.

NOW THIS AGREEMENT WITNESSETH AS FOLLOWS:

1. In this Agreement, words and expressions shall have the same meanings as are respectively assigned to them in the Conditions of Contract hereinafter referred to.
2. The following documents as required by the 2016 revised Implementing Rules and Regulations of Republic Act No. 9184 shall be deemed to form and be read and construed as part of this Agreement, viz.:
 - a. Philippine Bidding Documents (PBDs);
 - i. Drawings/Plans;
 - ii. Specifications;
 - iii. Bill of Quantities;
 - iv. General and Special Conditions of Contract;
 - v. Supplemental or Bid Bulletins, if any;
 - b. Winning bidder's bid, including the Eligibility requirements, Technical and Financial Proposals, and all other documents or statements submitted;

Bid form, including all the documents/statements contained in the Bidder's bidding envelopes, as annexes, and all other documents submitted (e.g., Bidder's response to request for clarifications on the bid), including corrections to the bid, if any, resulting from the Procuring Entity's bid evaluation;
 - c. Performance Security;
 - d. Notice of Award of Contract and the Bidder's conforme thereto; and
 - e. Other contract documents that may be required by existing laws and/or the Procuring Entity concerned in the PBDs. **Winning bidder agrees that additional contract documents or information prescribed by the GPPB that are subsequently required for submission after the contract execution, such as the Notice to Proceed, Variation Orders, and Warranty Security, shall likewise form part of the Contract.**
3. In consideration for the sum of *[total contract price in words and figures]* or such other sums as may be ascertained, *[Named of the bidder]* agrees to *[state the object of the contract]* in accordance with his/her/its Bid.
4. The *[Name of the procuring entity]* agrees to pay the above-mentioned sum in accordance with the terms of the Bidding.

IN WITNESS whereof the parties thereto have caused this Agreement to be executed the day and year first before written.

[Insert Name and Signature]

[Insert Name and Signature]

[Insert Signatory's Legal Capacity]

[Insert Signatory's Legal Capacity]

for:

for:

[Insert Procuring Entity]

[Insert Name of Supplier]

Acknowledgment

[Format shall be based on the latest Rules on Notarial Practice]

6. That the Joint Venture shall be known as _____
with business address at _____

7. That this Joint Venture Agreement shall remain in effect only for the above-stated
Contract until terminated by both parties.

IN WITNESS WHEREOF, we have hereunto set our hands this _____ day of
_____ 20____ at _____, Philippines.

(BUSINESS NAME OF JV PARTNER #1)

(BUSINESS NAME OF JV PARTNER #2)

BY: _____
(Proprietor/Gen. Mgr./President)

BY: _____
(Proprietor/Gen. Mgr./President)

W I T N E S S E S

A C K N O W L E D G M E N T

REPUBLIC OF THE PHILIPPINES)
) S.S

BEFORE ME, a Notary Public, for and in _____, Philippines personally
appeared:

<u>Comm. Tax Cert. No.</u>	<u>Date Issued</u>	<u>Place of Issue</u>
_____	_____	_____
_____	_____	_____

who are known to me and to me known to be the same persons who executed the
foregoing JOINT VENTURE AGREEMENT and acknowledged to me that the same are
their free and voluntary act and deed as well as the companies they represent. This
agreement, consisting of two (2) pages including this page where the acknowledgment
is written, have been signed by the parties and their instrumental witnesses in each and
every page hereof.

WITNESS MY HAND AND SEAL on this _____ day of _____, 20____ at
the place written above.

Doc. No. _____
Page No. _____
Book No. _____
Series of _____

NOTARY PUBLIC

JOINT VENTURE AGREEMENT

KNOW ALL MEN BY THESE PRESENTS:

That this JOINT VENTURE AGREEMENT is entered into by and between:

_____, of legal age, *(civil status)*, Owner/Proprietor/
General Manager/President of *(business name of JV partner #1)*
with business address at _____

- and -

_____, of legal age, *(civil status)*, Owner/Proprietor/
General Manager/President of *(business name of JV partner #2)*
with business address at _____

WITNESSETH:

1. That both parties agree to join together their capital, manpower, equipment, work experience and other resources and efforts to enable the Joint Venture to participate in the Eligibility Check, Bidding and Undertaking of the hereunder stated Contract of the *Philippine Ports Authority – PMO Palawan*:

(complete name/title of the contract to be bid)

2. That *(business name of JV partner #1)* shall contribute _____% and *(business name of JV partner #2)* shall contribute _____% of the logistics requirements of the Contract and the Joint Venture shall share the profit or loss on a _____ ratio;
3. That *(business name of JV partner #1)* and *(business name of JV partner #2)* shall assume joint and several responsibilities for the satisfactory performance of the Contract and the parties shall be jointly and severally liable to the Philippine Ports Authority – Head Office for all the obligations arising under the Contract;
4. That in case one of the parties declares bankruptcy or becomes insolvent, the remaining Joint Venture partner shall assume full responsibilities to undertake any correction works covered by the warranty;
5. That both parties agree that *(name of Authorized Managing Officer)* shall be the Official Representative and the Authorized Managing Officer and therefore the authorized signatory of the Joint Venture and is granted full power and authority to do, execute and perform any and all acts necessary and/or to represent the Joint Venture in the Eligibility Check, Bidding and Undertaking of the said Contract, as fully and effectively as the Joint Venture may do as if personally present with full power of substitution and revocation.